

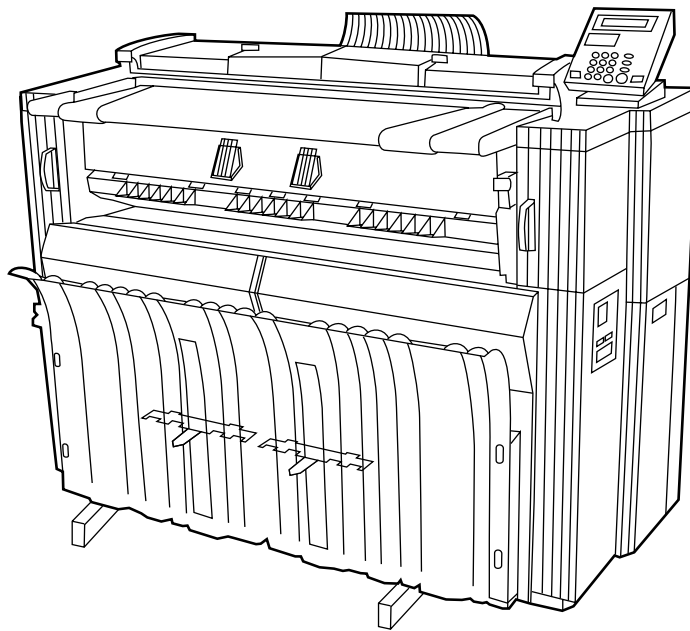

Operation Guide

KM-4850w



Please read the Operation Guide before using the copier.
Keep it in the designated location for easy reference.



As an ENERGY STAR Partner, KYOCERA MITA CORPORATION has determined that this product meets the ENERGY STAR guidelines for energy efficiency. The ENERGY STAR program is an energy reduction plan introduced by the United States Environmental Protection Agency in response to environmental issues and for the purpose of advancing the development and utilization of more energy efficient office equipment.

* ENERGY STAR is a U.S. registered mark.

The Auto-Shut-off time setting becomes 15 to 120 minutes in the areas corresponding to the Swiss Energy 2000 program.

All rights reserved. No part of this material may be reproduced or transmitted in any form or by any means, electronic or mechanical, including photocopying, recording or by any information storage and retrieval system, without permission in writing from the Publisher.

Legal Restriction On Copying

- It may be prohibited to copy copyrighted material without permission of the copyright owner.
- It is prohibited under any circumstances to copy domestic or foreign currencies.
- Copying other items may be prohibited.

NOTICE

This Operation Guide contains information that corresponds to using both the inch and metric versions of this machine. Since the messages and terminology on those respective operation panels differs between these two versions, for purposes of clarification and easier understanding we have listed the message displays and operation panels used in BOTH types of machine. However, in the main text of this guide, when the difference in a name or message is only one of upper- and lowercase spelling, we have listed the information as it specifically pertains to the inch version of this machine. When there is even a slight difference in the message, key/indicator name or other specifications, we have listed the information for the inch version followed, in brackets, by the corresponding information for the metric version.

Please read the Operation Guide before using the copier. Keep it in the designated location for easy reference.

The sections of this handbook and parts of the copier marked with symbols are safety warnings meant to protect the user, other individuals and surrounding objects, and ensure correct and safe usage of the copier. The symbols and their meanings are indicated below.



⚠ DANGER: Indicates that serious injury or even death will very possibly result from insufficient attention to or incorrect compliance with the related points.

⚠ WARNING: Indicates that serious injury or even death may result from insufficient attention to or incorrect compliance with the related points.



⚠ CAUTION: Indicates that personal injury or mechanical damage may result from insufficient attention to or incorrect compliance with the related points.

Symbols



The \triangle symbol indicates that the related section includes safety warnings. Specific points of attention are indicated inside the symbol.

-  [General warning]
-  [Warning of danger of electrical shock]
-  [Warning of high temperature]

The \circ symbol indicates that the related section includes information on prohibited actions. Specifics of the prohibited action are indicated inside the symbol.

-  [Warning of prohibited action]
-  [Disassembly prohibited]

The \bullet symbol indicates that the related section includes information on actions which must be performed. Specifics of the required action are indicated inside the symbol.

-  [Alert of required action]
-  [Remove the power plug from the outlet]
-  [Always connect the copier to an outlet with a ground connection]

Please contact your service representative to order a replacement if the safety warnings in the handbook are illegible or if the handbook itself is missing. (fee required)

Contents

CHAPTER 1 IMPORTANT! PLEASE READ FIRST.	1-1
▲ CAUTION LABELS	1-1
▲ INSTALLATION PRECAUTIONS	1-2
▲ PRECAUTIONS FOR USE	1-3
CHAPTER 2 NAMES OF PARTS	2-1
(1) Main body	2-1
(2) Operation panel	2-4
(3) Message display	2-6
CHAPTER 3 PREPARATIONS	3-1
1. Originals	3-1
(1) Type of originals	3-1
(2) Setting the Original Loop Guide	3-2
(3) Setting the Original Holders	3-2
(4) How to Set an Original	3-2
(5) How to Use the Carrier Sheet (option)	3-3
(6) How to Use the Original Tray (option)	3-4
2. Paper	3-5
(1) Paper Types	3-5
(2) How to Set Paper Roll	3-6
(3) Dew prevention heater	3-7
(4) How to Use the Copy Tray Support Plate	3-8
CHAPTER 4 BASIC COPYING	4-1
1. Before starting copying	4-1
(1) Initial state	4-1
(2) When the Energy Saver indicator is lit	4-1
(3) When using a key counter (option)	4-1
2. Basic Copying	4-2
3. Copy Modes	4-4
(1) APS mode	4-4
(2) AMS mode	4-4
(3) Manual mode	4-4
4. Paper Material Selection	4-5
5. Paper Roll Cut Length Selection	4-6
(1) Synchronized cut	4-6
(2) Standard cut	4-6
(3) Numeric key input	4-7
6. Bypass Copy	4-8
7. Canceling Copying	4-9
CHAPTER 5 FUNCTIONAL COPYING	5-1
1. Zoom mode	5-1
(1) Standard zoom	5-1
(2) User setting zoom	5-3
(3) XY zoom	5-3
(4) Zoom	5-4
2. Editing Functions	5-5
(1) Image shift	5-5
(2) Margin copy	5-7
● Leading edge margin	5-7
● Trailing edge margin	5-7
● Whole sheet print	5-7
(3) Border Erase mode	5-9
(4) Mirror mode	5-10
(5) Rotation mode	5-11
3. Sort/Group copy	5-12
(1) Sort copy	5-12
(2) Group copy	5-13

CHAPTER 6 CONVENIENT FUNCTIONS	6-1
1. Adjustment Functions	6-1
(1) Inclination adjustment	6-1
(2) Copy size fine adjustment	6-2
(3) Fixing Temperature Fine Adjustment	6-3
2. Repeat Copy Function	6-4
(1) How to make a repeat copy	6-4
(2) Repeat copy after sort/group	6-4
(3) Deleting Image Data	6-5
3. Preview Copy	6-6
● Preview image	6-6
● Preview contrast	6-6
4. Job Reserve Function	6-7
(1) Reserving a job	6-7
(2) Canceling job reserve	6-8
5. Program Function	6-9
(1) Registering a program	6-9
(2) Program Recall	6-10
6. Interrupt Copy	6-11
7. Auto Clear Function	6-12
8. Energy Saver Function	6-12
9. Auto Shut-off Function	6-12

CHAPTER 7 MANAGEMENT AND SETTING	7-1
1. List of Default Setting	7-1
(1) Machine default	7-1
(2) Copy default	7-4
2. Setting Method of Default Setting	7-8
(1) Setting method for user	7-8
(2) Setting method for manager	7-9
(3) Setting of each item	7-10
3. Language Switching	7-24

CHAPTER 8 TROUBLESHOOTING	8-1
1. Messages during Copying	8-1
2. Replenishing the Toner	8-3
3. Replacing the Waste Toner Tank	8-5
4. Countermeasures against Memory Overflow	8-6
5. Countermeasures against Call for service Message ..	8-8
6. When Paper or an Original Jams	8-9
(1) Jam location display	8-9
(2) Cautions	8-9
(3) Removal procedure	8-9
7. Troubleshooting	8-14

CHAPTER 9 MAINTENANCE AND MANAGEMENT	9-1
1. Cleaning the Machine	9-1
2. Specifications	9-2

● USING THE ADVANCED FEATURES OF THIS COPIER

■ Copier features

- 1** <Auto Paper Selection mode> (Page 4-2)
To make the machine select paper automatically.

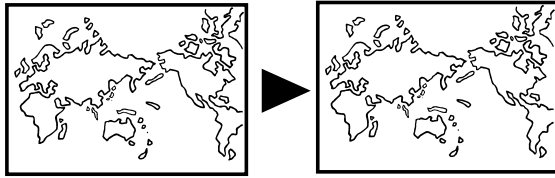

- <Independent Zoom mode>(Page 5-3)
To enlarge/reduce copies to separate lengthwise and widthwise ratios.

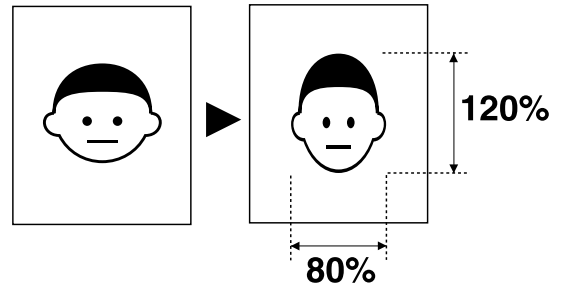

- 2** A variety of enlargement/reduction functions
<Auto Zoom mode>(Page 4-4)
To enlarge/reduce copies to a specified paper size.

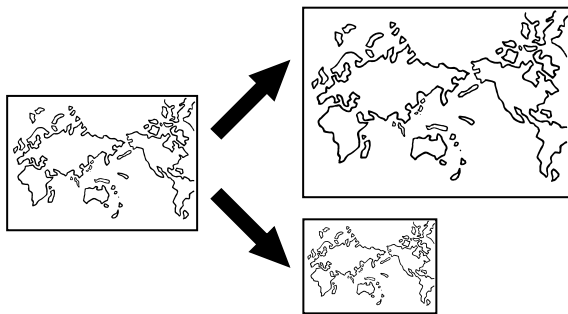

- 3** <Sort copy>(Page 5-12)
To copy multiple originals to multiple collated sets.

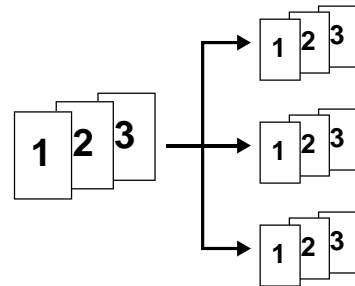

- 4** <Group copy>(Page 5-13)
To make multiple copies grouped by original.

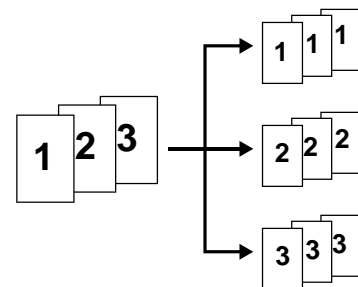

- <Numeric key/zoom key input>(Page 5-4)
To enlarge/reduce copies in 1% or 0.1% increments.

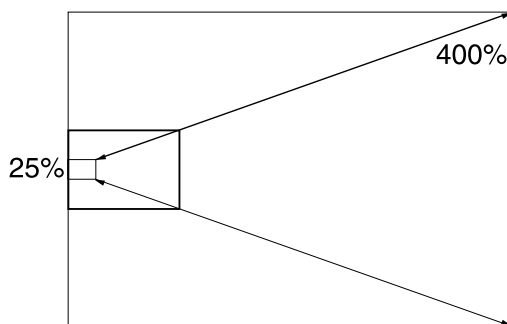

- 5** <Image Shift mode>(Page 5-5)
To shift the image up, down, to the right or to the left.

- <Preset R/E mode>(Page 5-1)
To enlarge/reduce copies to preset ratios.

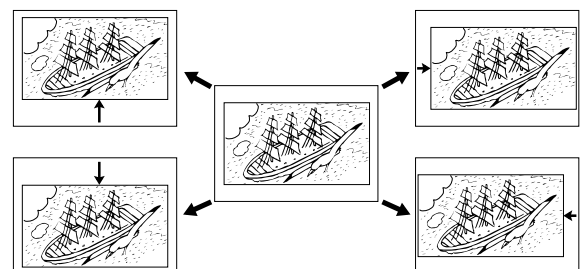

● USING THE ADVANCED FEATURES OF THIS COPIER

- 6** <Margin Copy mode>(Page 5-7)
To make margins at the leading or trailing edge in copies. Also to cut margins.

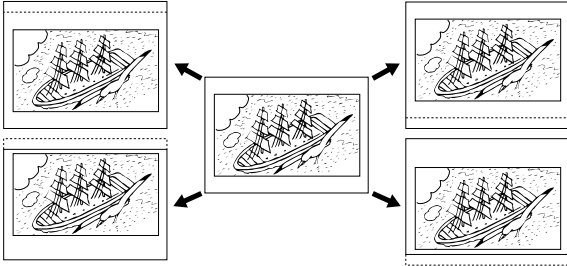

- 10** <Preview Copy mode>(Page 6-6)
To make a sample copy to verify the contrast.

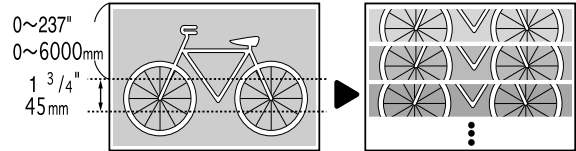
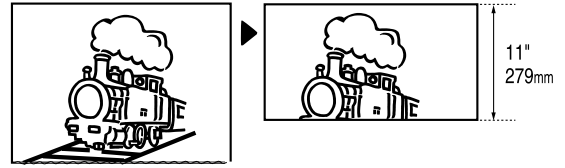

- 7** <Border Erase mode>(Page 5-9)
To make neat copies without blemishes around edges.

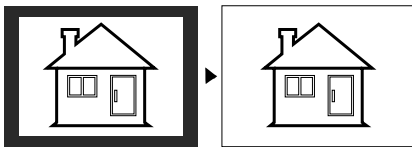

- 11** <Repeat Copy function>(Page 6-4)
To make repeated copies after making one copy.

- 12** <Job Reserve function>(Page 6-7)
To reserve an additional copy job while a copy job is being run.

- 8** <Mirror mode>(Page 5-10)
To make mirror-image copies.

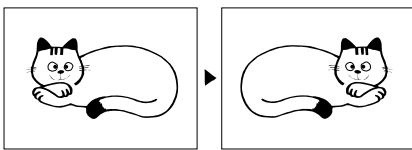

- 13** <Program function>(Page 6-9)
To register frequently used settings.

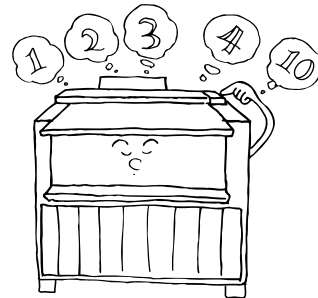

- 9** <Rotation mode>(Page 5-11)
To rotate images by 90°

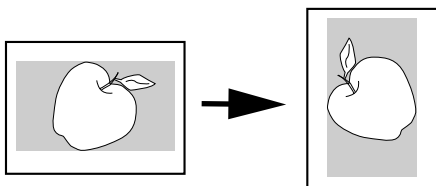

■ **Setting/adjustment features**

14 <Fixing temperature adjustment>(Page 7-2)
To set the fixing temperature based on the paper material and the installation environment of the machine.

15 <Fixing temperature fine adjustment>(Page 6-3)
To make temporarily fine adjustments for fixing temperature.

16 <Copy size adjustment>(Page 7-2)
To adjust the copy size based on the paper material and the installation environment of the machine.

17 <Copy size fine adjustment>(Page 6-2)
To make temporarily fine adjustments for copy size.

18 <Inclination adjustment>(Page 6-1)
To correct the inclination between 1.5° to the left and 1.5° to the right.

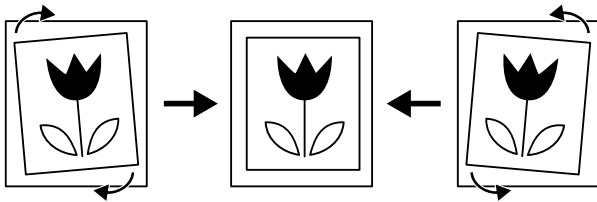

21 <Key counter>(Page 4-1)
To count the number of output sheets.

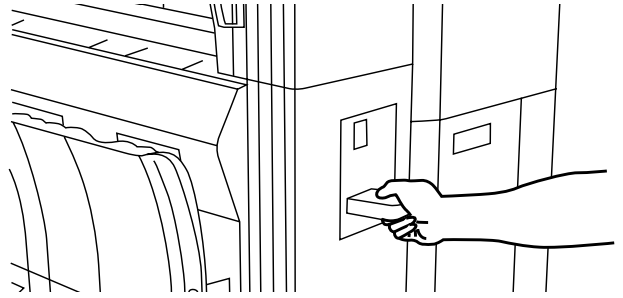

22 <Carrier sheet>(Page 3-3)
To protect an original when it is fed.

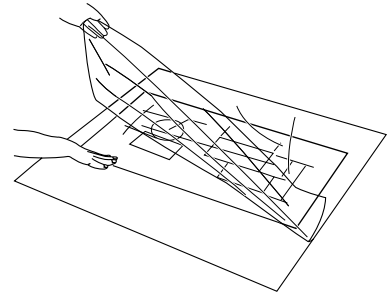

23 <Expansion memory>
To add DIMM (128 MB, 256 MB or 512 MB) into up to 2 slots.

■ **Options**

19 <Roll unit>(Page 3-6)
To add a paper source.

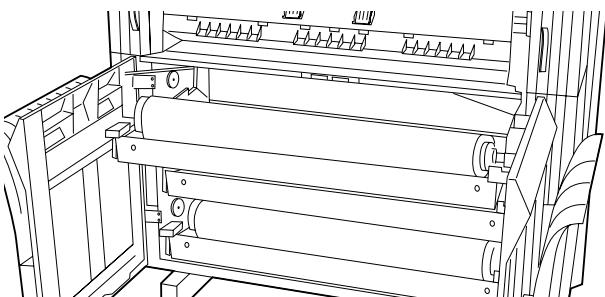

20 <Original tray>(Page 3-4)
To collect originals ejected from the rear of the machine.

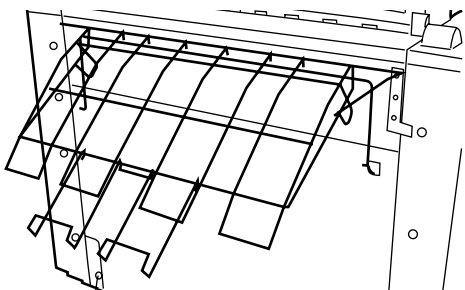

24 <Printer/scanner controller>
To use this machine as a printer or a scanner.

CHAPTER 1 IMPORTANT! PLEASE READ FIRST.

CAUTION LABELS

Caution labels have been attached to the copier at the following locations for safety purposes. BE SUFFICIENTLY CAREFUL to avoid fire or electric shock when removing a paper jam.

Label 1
High temperature inside. Do not touch parts in this area, because there is a danger of getting burned.....

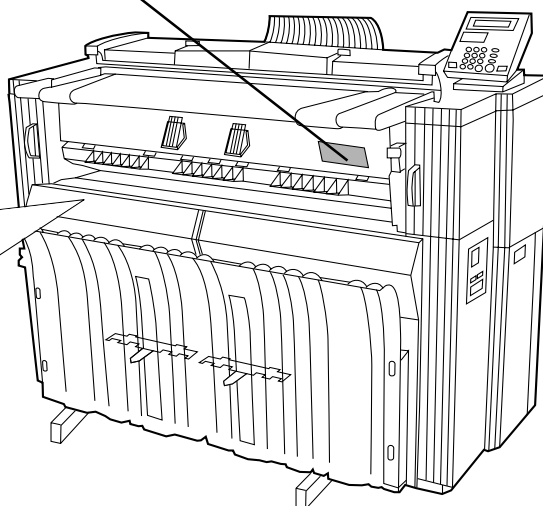
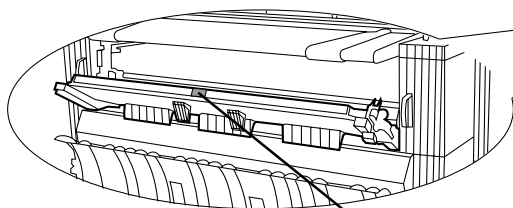

Label 2, 3
High temperature inside. Do not touch parts in this area, because there is a danger of getting burned.....

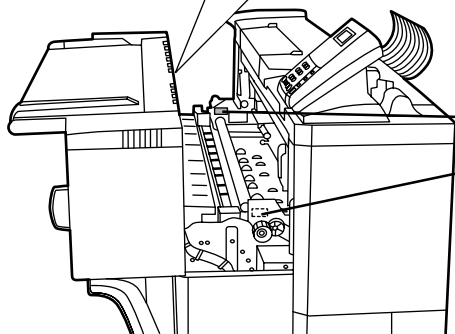
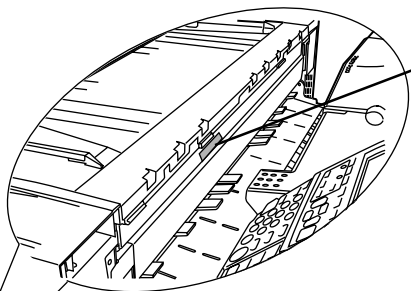

Label 4, 5
High voltage inside. NEVER touch parts in this area, because there is a danger of electric shock.
.....







NOTE: DO NOT remove these labels.

INSTALLATION PRECAUTIONS

■ Environment

CAUTION

- Avoid placing the copier on or in locations which are unstable or not level. Such locations may cause the copier to fall down or fall over. This type of situation presents a danger of personal injury or damage to the copier. 
- Avoid locations with humidity or dust and dirt. If dust or dirt become attached to the power plug, clean the plug to avoid the danger of fire or electrical shock. 
- Avoid locations near radiators, heaters, or other heat sources, or locations near flammable items, to avoid the danger of fire. 
- To keep the copier cool and facilitate changing of parts and maintenance, allow access space as shown below. Leave adequate space, especially around the left right and rear covers, to allow air to be properly ventilated out of the copier. 

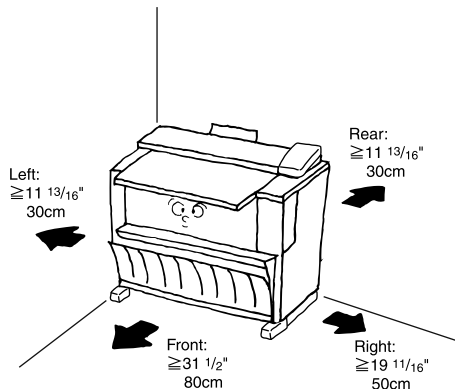



- Always use the caster stoppers to stabilize the copier once it is in place to keep it from moving and/or falling over and causing injury. 

Other precautions

- Adverse environmental conditions may affect the safe operation and performance of the copier. Install in an air-conditioned room (recommended room temperature: around 68°F[20°C], humidity: around 65%RH) and avoid the following locations when selecting a site for the copier.
 - . Avoid locations near a window or with exposure to direct sunlight.
 - . Avoid locations with vibrations.
 - . Avoid locations with drastic temperature fluctuations.
 - . Avoid locations with direct exposure to hot or cold air.
 - . Avoid poorly ventilated locations.
- If the floor is delicate against casters, when this product is moved after installation, the floor material may be damaged.

■ Power supply/Grounding the copier

WARNING

- DO NOT use a power supply with a voltage other than that specified. Avoid multiple connections in the same outlet. These types of situations present a danger of fire or electrical shock. 
- Plug the power cord securely into the outlet. If metallic objects come in contact with the prongs on the plug, it may cause a fire or electric shock. 
- Always connect the copier to an outlet with a ground connection to avoid the danger of fire or electrical shock in case of an electric short. If an earth connection is not possible, contact your service representative. 

Other precautions

- Connect the power plug to the closest outlet possible to the copier.
- The power supply cord is used as the main disconnect device. Ensure that the socket/outlet is located/installed near the equipment and is easily accessible.

■ Handling of plastic bags

WARNING









- Keep the plastic bags that are used with the copier away from children. The plastic may cling to their nose and mouth causing suffocation. 









PRECAUTIONS FOR USE

■ Cautions when using the copier

WARNING

- DO NOT place metallic objects or containers with water (flower vases, flower pots, cups, etc.) on or near the copier. This type of situation presents a danger of fire or electrical shock should they fall inside. 
- DO NOT remove any of the covers from the copier as there is a danger of electrical shock from high voltage parts inside the copier. 
- DO NOT damage, break or attempt to repair the power cord. DO NOT place heavy objects on the cord, pull it, bend it unnecessarily or cause any other type of damage. These types of situations present a danger of fire or electrical shock. 
- NEVER attempt to repair or disassemble the copier or its parts as there is a danger of fire, electrical shock or damage to the laser. 
- If the copier becomes excessively hot, smoke appears from the copier, there is an odd smell, or any other abnormal situation occurs, there is a danger of fire or electrical shock. Turn the main switch OFF (O) immediately, remove the power plug from the outlet and contact your service representative. 
- If anything harmful (paper clips, water, other fluids, etc.) falls into the copier, turn the main switch OFF (O) immediately. Next, remove the power plug from the outlet to avoid the danger of fire or electrical shock. Then contact your service representative. 
- DO NOT remove or connect the power plug with wet hands, as there is a danger of electrical shock. 
- ALWAYS contact your service representative for maintenance or repair of internal parts. 

CAUTION





- DO NOT pull the power cord when removing it from the outlet. If the power cord is pulled, the wires may become broken and there is a danger of fire or electrical shock. (ALWAYS grasp the power plug when removing the power cord from the outlet.) 
- ALWAYS remove the power plug from the outlet when moving the copier. If the power cord is damaged, there is a danger of fire or electrical shock. 
- If the copier will not be used for a short period of time (overnight, etc.), turn the main switch OFF (O). If it will not be used for an extended period of time (vacations, etc.), remove the power plug from the outlet for safety purposes during the time the copier is not in use. 
- When moving the copier, turn the leveler bolts to keep them away from the floor. 
- For safety purposes, ALWAYS remove the power plug from the outlet when performing cleaning operations. ... 
- If dust accumulates within the copier, there is a danger of fire or other trouble. It is therefore recommended that you consult with your service representative in regard to cleaning of internal parts. This is particularly effective if accomplished prior to seasons of high humidity. Consult with your service representative in regard to the cost of cleaning the internal parts of the copier. ... 

Other precautions

- DO NOT place heavy objects on the copier or cause other damage to the copier.
- DO NOT open the front cover, turn off the main switch, or pull out the power plug during copying.
- During copying, some ozone is released, but the amount does not cause any ill effect to one's health. If, however, the copier is used over a long period of time in a poorly ventilated room or when making an extremely large number of copies, the smell may become unpleasant. To maintain the appropriate environment for copy work, it is suggested that the room be properly ventilated.
- When lifting or moving the copier, contact your service representative.
- Do not touch electrical parts, such as connectors or printed circuit boards. They could be damaged by static electricity.
- DO NOT attempt to perform any operations not explained in this handbook.
- CAUTION : Use of controls or adjustments or performance of procedures other than those specified herein may result in hazardous radiation exposure.

■ Cautions when handling consumables

CAUTION

- Avoid inhalation, ingestion, skin or eye contact. If ingestion occurs, dilute stomach contents thoroughly with water and seek medical treatment. If skin contact occurs, wash with soap and water. If contact with eyes occurs, flush thoroughly with water and seek medical treatment. 
- Prolonged inhalation of excessive dusts may cause lung damage. Use of this product, as intended, does not result in inhalation of excessive dusts. 
- Keep away from children. 
- Do not incinerate toner and toner containers. Dangerous sparks may cause burn. 

Other precautions

- Always read the safety instructions which are included in the box or printed on the container when handling consumables.
- Dispose of the toner or toner containers in accordance with Federal, State and Local rules and regulations.
- Store consumables in a cool, dark location.
- If the copier will not be used for an extended period of time, remove the paper from the cassette, return it to its original package and reseal it.

CHAPTER 2 NAMES OF PARTS

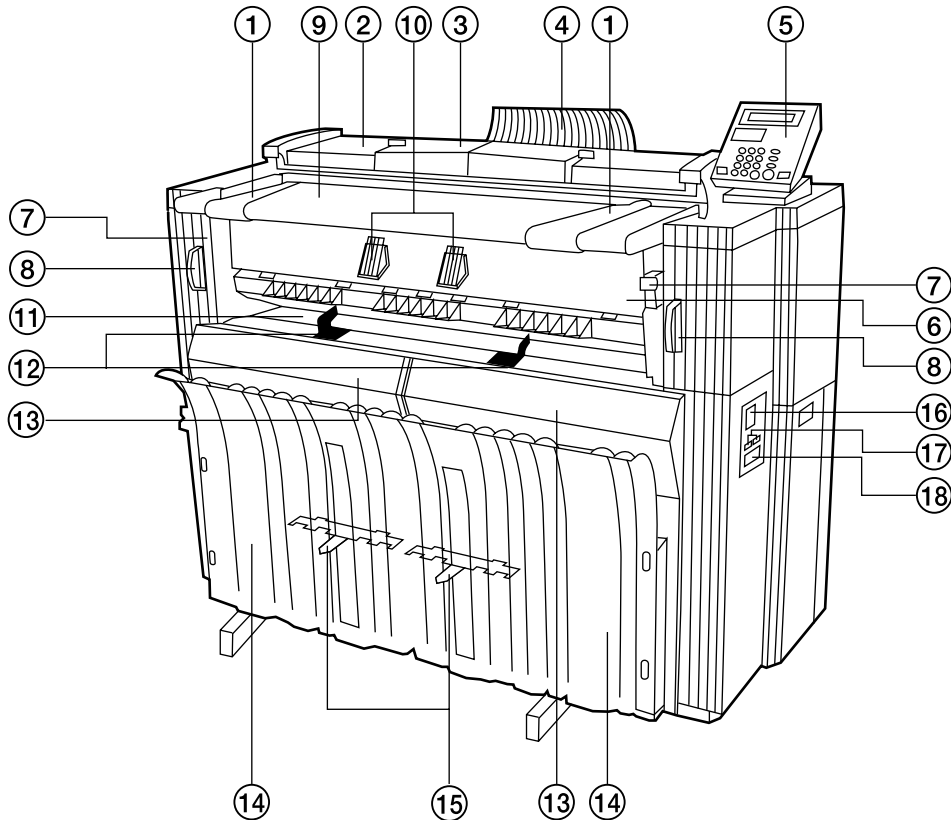

(1) Main body

- ① Original guide
- ② Original cover
- ③ Original leading edge cover
Open to set an original with precision.
- ④ Original loop guide
- ⑤ Operation panel
- ⑥ Ejection cover
Open in the case of a paper jam.
- ⑦ Ejection release lever
Operate this lever in the case of a paper jam.
- ⑧ Main body release lever
Operate this lever in the case of a paper jam.
- ⑨ Original table
- ⑩ Original holders
A long rolled original can be set.
- ⑪ Bypass table
- ⑫ Bypass guide
- ⑬ Front cover
Open to set paper roll or in the case of a paper jam.
- ⑭ Copy tray
Copies are delivered here.
- ⑮ Copy tray support plate
Set in accordance with the paper size for copying.
- ⑯ Main power switch
- ⑰ Total counter
This indicates the paper output length.
- ⑱ Key counter insert slot
When a key counter (option) is installed, set the key counter here.

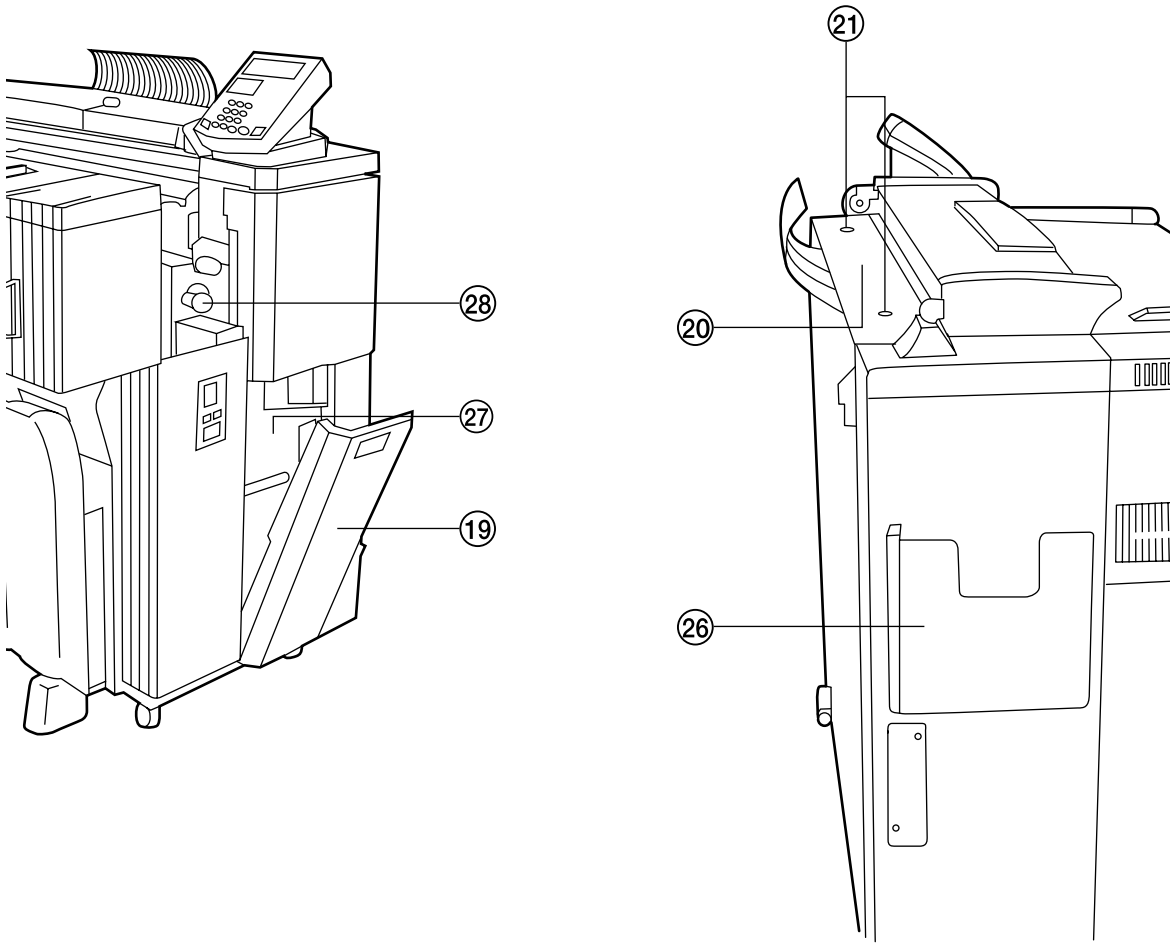

- ①⑨ Right cover
Open to replace the waste toner tank.
- ②⑩ Toner replenishing slot
Open to add toner.
- ②① Toner replenishing slot screw
Turn to open the toner replenishing slot.
- ②② Contact glass (Originals are scanned here.)
- ②③ Roll unit (paper source 1: option)
- ②④ Roll unit (paper source 2)
- ②⑤ Roll unit (paper source 3)
- ②⑥ Instruction handbook box
Keep the instruction handbook here.
- ②⑦ Waste toner tank
- ②⑧ Paper transport knob
Operate this knob in the case of a paper jam.
- ②⑨ Dew prevention heater switches
Switches for paper sources 1, 2, and 3 from the top.
- ③⑩ Main heater switch
If this switch is turned off, the dew prevention heaters will be turned off even if the dew prevention heater switches inside the front cover are on.
- ③① Flanges
Set these on both sides of paper roll.
- ③② Release levers
- ③③ Flange guides

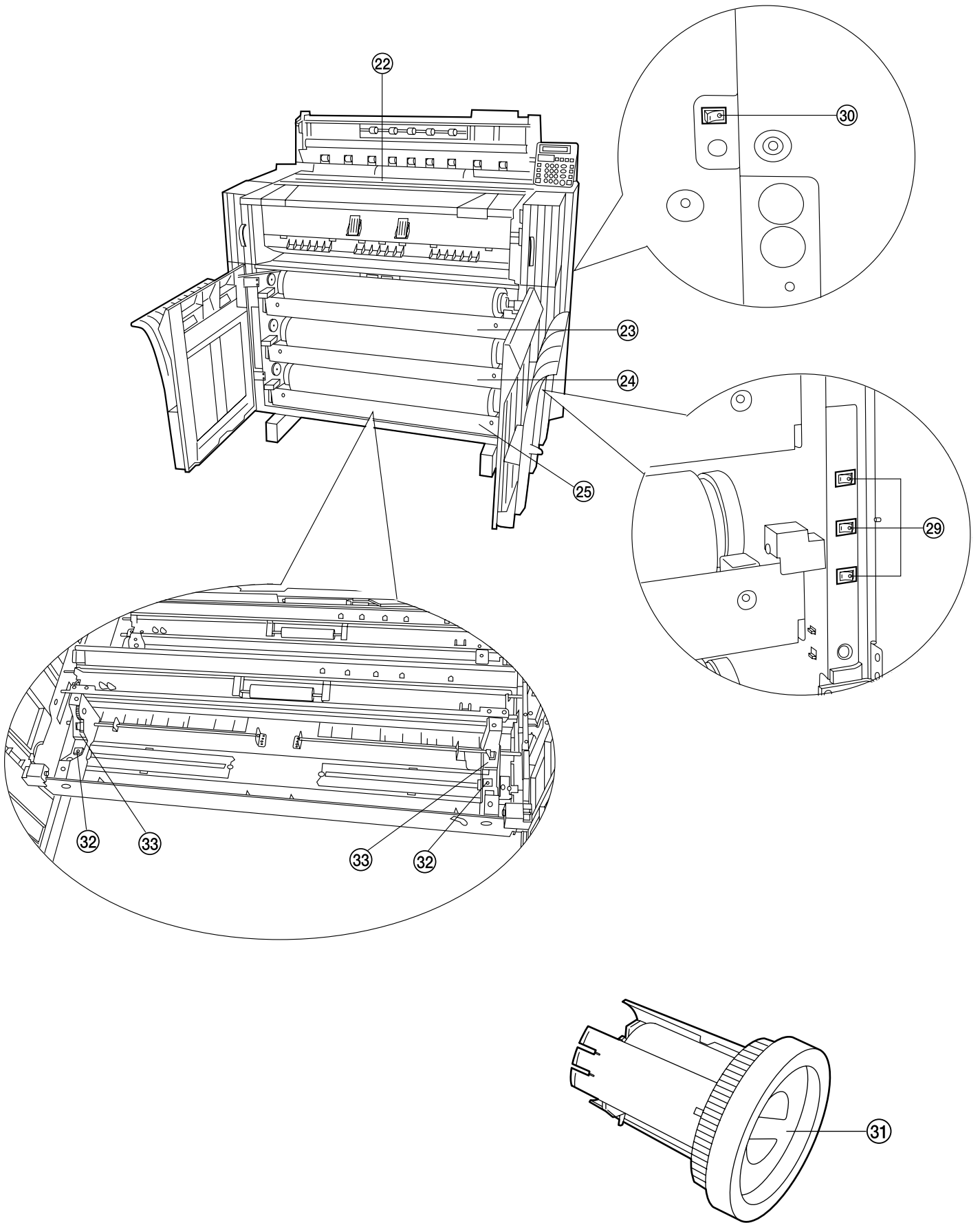

(2) Operation panel

Inch

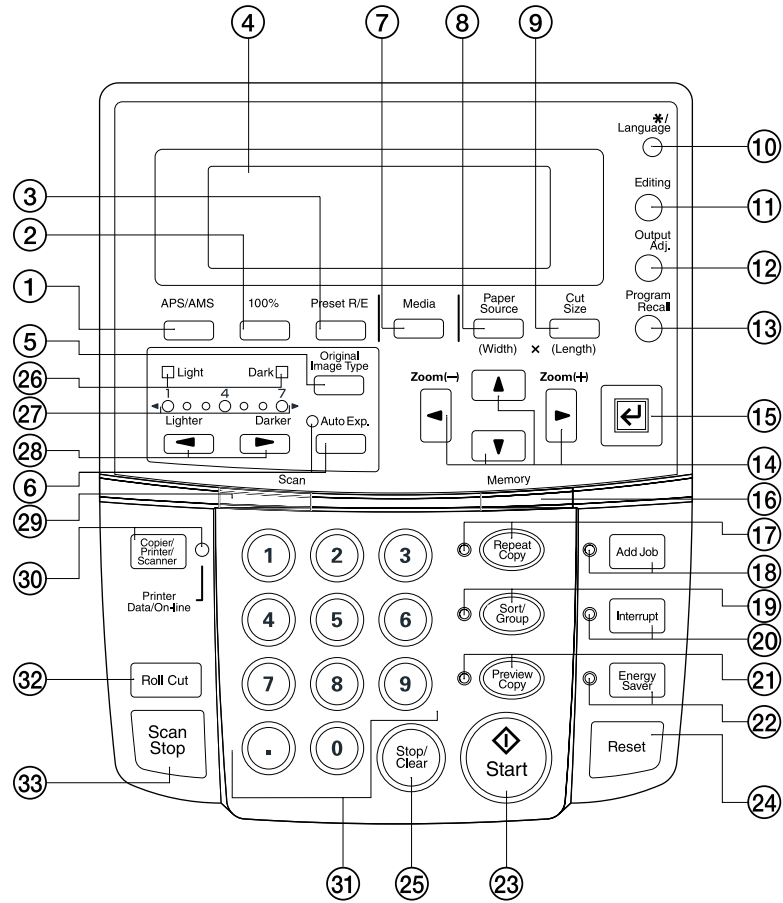

Metric

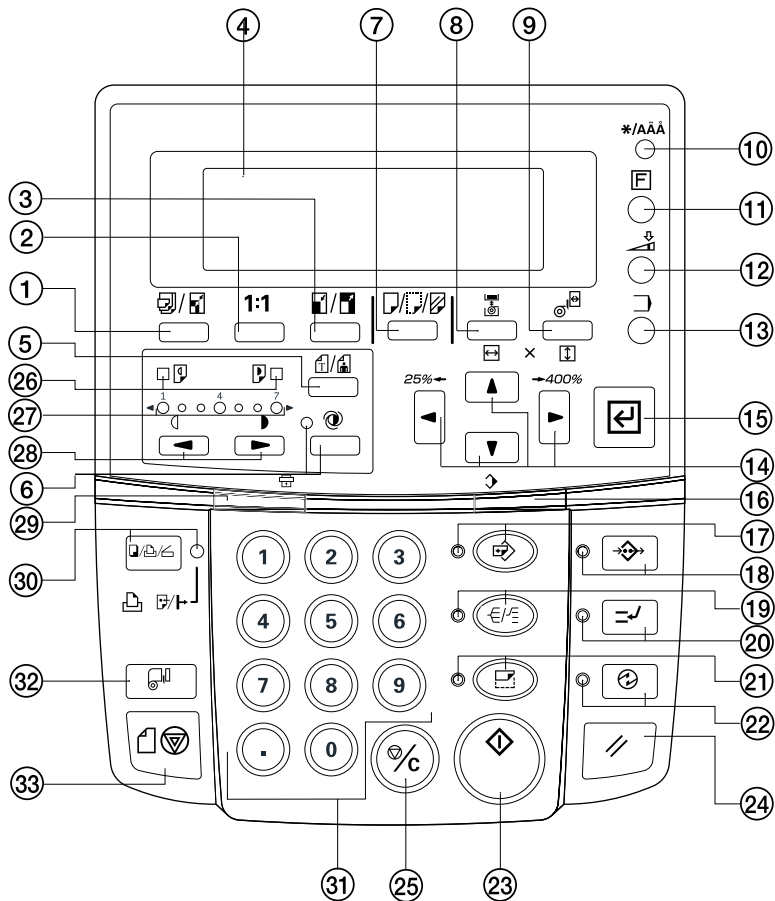

- ① APS/AMS key
(Press this key to switch between the auto paper selection mode and the auto zoom mode. Page 4-4)
- ② 100% key
(Press this key to set the magnification ratio to 100% for copying.)
- ③ Preset R/E key
(Press this key to change the magnification ratio for copying. Page 5-1)
- ④ Message display
(Copy conditions and errors such as a paper jam are displayed here.
NOTE: When using the copier at a low temperature of lower than 41°F [5°C], the display may not be clearly seen. In this case, adjust the contrast using "⑤ Display contrast" of the default setting. Page 7-1)
- ⑤ Original Image Type key
(Press this key to select an original type from normal original, text, and photo. Proper image processing based on the original type will be performed. Page 4-2)
- ⑥ Auto Exp. key/indicator
(Press this key to set the exposure automatically. Page 4-3)
- ⑦ Media key
(Press this key to select a paper material from bond paper, vellum, film, and custom. Page 4-2, 4-5)
- ⑧ Paper Source key
(Press this key to select a paper source from paper source 1 (option), paper source 2, paper source 3, and bypass. Page 4-2)
- ⑨ Cut Size key
(Press this key to select the cut size from the three types: synchronized cut, standard size cut, and numeric key input (custom size). Page 4-2, 4-6)
- ⑩ */Language key
(Press this key to register a default setting or a program or to change the language.)
- ⑪ Editing key
(Press this key to use an editing function such as image shift, margin copy, border erase, mirror, and image rotation. Page 5-5)
- ⑫ Output Adj. key
(Press this key to use inclination adjustment, copy size fine adjustment or fixing temperature fine adjustment. Page 6-1)
- ⑬ Program Recall key
(Press this key to recall a registered program. Page 6-10)
- ⑭ ▲▼◀▶ (cursor) keys
(Use these keys to select a choice in various setting modes. Also use these keys to change the magnification ratio.)
- ⑮ OK key
(Use to confirm the setting in various setting modes.)
- ⑯ Memory indicator
(Indicates the status of use of image memory.
Lit: Image has been stored in memory.
Off: No image is stored in memory.
Blinking: Image is being stored in memory.)
- ⑰ Repeat copy key/indicator
(Press this key to make repeated copies. Page 6-4)
- ⑱ Add job key/indicator
(Press this key to use the job reserve function. Page 6-7)
- ⑲ Sort/Group key/indicator
(Press this key to select sort or group copy. The Sort/Group indicator will light up. Page 5-12)
- ⑳ Interrupt key/indicator
(Press this key to interrupt copying. The Interrupt indicator will light up. Page 6-11)
- ㉑ Preview Copy key/indicator
(Press this key to make a sample copy. The Preview Copy indicator will light up. Page 6-6)
- ㉒ Energy Saver key/indicator
(Press this key to enter or exit the energy saver mode. The Energy Saver indicator will light up. Page 4-1)
- ㉓ Start key
(Press this key to start scanning or output.)
- ㉔ Reset key
(Press this key to cancel the preset functions. Image data stored in the image memory will also be cleared.)
- ㉕ Stop/Clear key
(Press this key to clear the number of copies or to stop copying in progress.)
- ㉖ Light/Dark indicators
(Indicate the status of the manual exposure mode.
Light indicator is lit: standard light mode
Dark indicator is lit: standard dark mode
Page 4-3)
- ㉗ Copy contrast indicators
(Indicate the copy contrast in the manual exposure mode. Left indicators indicate lighter exposure levels and right indicators indicate darker exposure levels.)
- ㉘ Copy contrast keys
(Press to adjust the copy contrast in the manual exposure mode. Page 4-3)
- ㉙ Scan indicator
(Indicates the status of scanning of originals.)
Lit: Scanning is possible.
Off: Scanning is impossible.
Blinking: An original is being scanned.)
- ㉚ Copier/Printer/Scanner key/indicator
(Press this key to switch to the printer or scanner mode when an optional interface unit is installed. The indicator will light up.)
- ㉛ Numeric keys
(Press these keys to enter the number of copies or other numerical values.)
- ㉜ Roll Cut key
(Press this key when a new paper roll is set. Also press to cut paper roll by force during output and to cancel copying. Page 4-2, 4-6)
- ㉝ Scan stop key
(Press this key to stop immediately transfer of originals. Page 4-9)

● **Auto roll over function**

If paper of the same size is set in multiple paper sources, when paper runs out in a paper source during copying, another paper source will be automatically selected and copying will continue. If an optional roll unit is installed, the unit can also be used for this function similarly to the standard roll units.

* This function can be enabled or disabled by using “⑭ Auto roll over” of the default setting. (Page 7-3)

● **Auto clear function**

When one minute elapses after a copy run is complete, the machine will automatically return to the initial settings.

* This function can be enabled or disabled by using “⑦ Auto clear”. (Page 7-2)

* The time for this function can be set by using “⑨ Timer set”. (Page 7-2)

(3) Message display

(Inch)

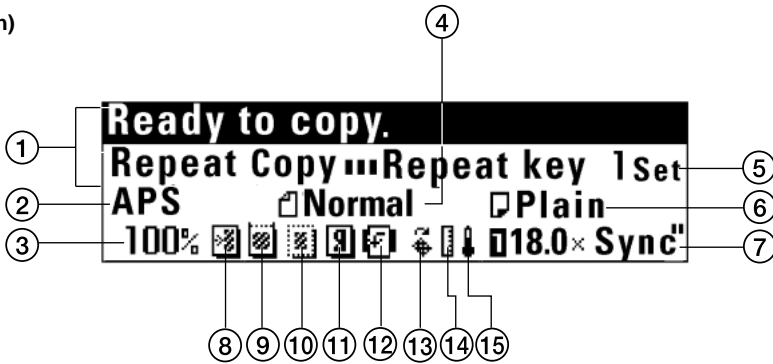

(Metric)

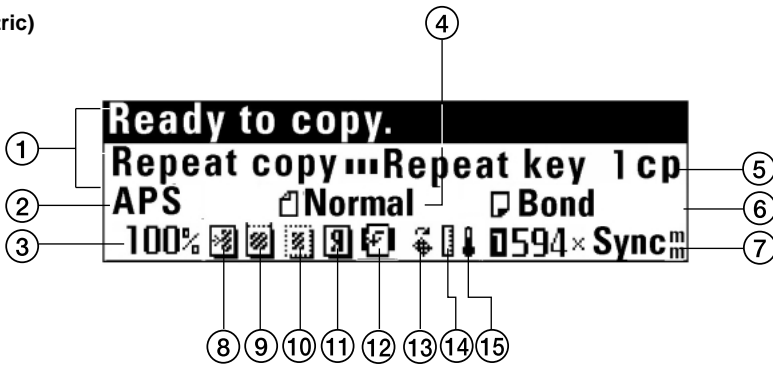

① Indicates the status of the machine and copying.

② Indicates the copy mode.
 “APS”: Auto paper selection mode
 “AMS”: Auto zoom mode

③ Indicates the type of originals.
 “Normal original”, “Text” or “Photo”

④ Indicates the magnification ratio.

⑤ Indicates the number of copies.

⑥ Indicates the paper material.
 “Plain” (“Bond paper”), “Vellum”, “Film” or “Custom”

⑦ Indicates the paper size and paper sources.

● **Currently set copier features and adjustment features**

- ⑧ Image shift setting
- ⑨ Margin copy setting
- ⑩ Border erase setting
- ⑪ Mirror setting
- ⑫ Image rotation setting
- ⑬ Inclination adjustment
- ⑭ Copy size fine adjustment
- ⑮ Fixing temperature fine adjustment

CHAPTER 3 PREPARATIONS

1. Originals

(1) Type of originals

Note the following restrictions on the originals that can be used in this machine.

● Acceptable originals

- Only sheet type originals can be used.
- Original sizes in standard sizes are 8 1/2" x 11" to 36" x 48" [A4 portrait to A0]
- Original thickness is 64 to 80 g/m².
- Original length is 11" to 237" [279 to 6000 mm].
- Original width is 8 1/2" to 36" [210 to 920 mm].

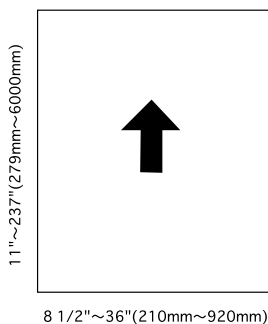

● Carrier sheet (option)

Use the carrier sheet when copying from the following types of originals. It is also recommended for use with any other delicate or important originals or when making multiple copies from the same originals. For explanation on how to use the carrier sheet, see "(5)Carrier Sheet (option)". (Page 3-3)

- Thin, flimsy or fragile originals
- Carbon paper
- Originals with severe wrinkles or folds
- Originals with punch holes or perforations
- Originals with other paper, etc., pasted on it
- Piled originals

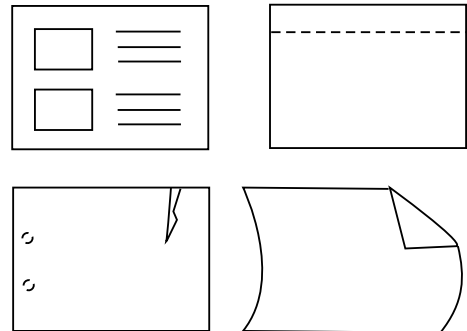

NOTE

- Number of originals that can be scanned for sort copying (for reference)

Memory compression setting	Number of originals that can be scanned (36" x 48" [A0])
High-compression	Approx. 8 sheets
Standard-compression	Approx. 2 sheets

The number of originals above is a value for reference in case of standard memory capacity (128 MB). The value varies with the original feed conditions and the type of originals.

- The compression ratio of image data in memory can be changed by using "⑲ Memory compress [Repeat code change]" of the default setting. If "Non-compression" is selected, addition of memory is needed.

NOTE

- When copying a film type original repeatedly, be sure to use the carrier sheet to prevent soil due to static electricity.
- When copying an original on which text has been written in pencil, it is recommended to use the carrier sheet to prevent soil of the original.

● Do not use the following originals.

- Originals of sizes other than the sizes described as acceptable originals
- Originals with staples or clips
- Wet originals or originals with adhesive tape, or glue
- Originals with uneven thickness
- Original wet with ink or correction fluid

For originals processed around the edges, the leading and trailing edges are wavy. Images in these areas may be isolated or missing. In this case, set the original so that the edge that is less wavy is placed as the leading edge.

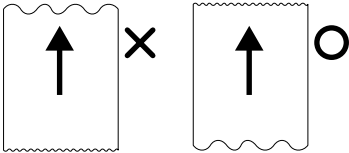

(2) Setting the Original Loop Guide

The original loop guide returns the originals ejected to the rear of the machine toward the front side.

* When using an original tray (option) or a carrier sheet (option) and when “⑥ Orig.eject direct” of the default setting is set to “Discharge to front”[Output to front], remove the original loop guide.

Set the guide on the rear side of the machine.

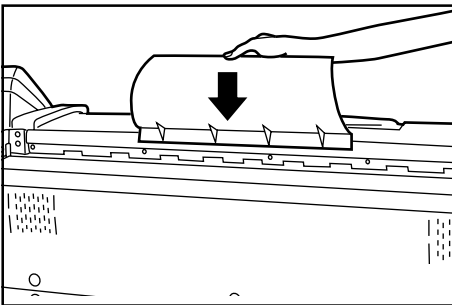

(3) Setting the Original Holders

When copying a long rolled original, open the original holders on both sides and use them.

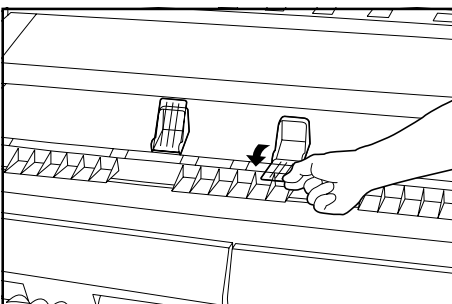

(4) How to Set an Original

- 1 Adjust both the original guides to the original size indications on the original table.

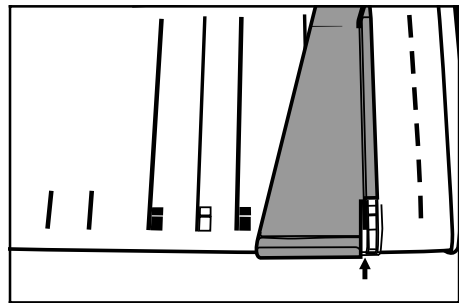
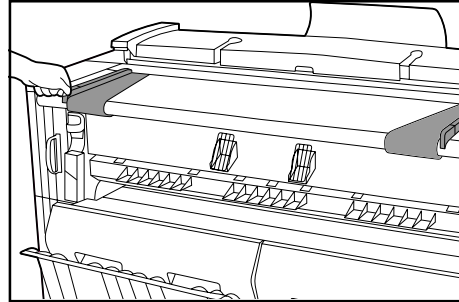

- 2 Set an original face down. When automatic start is activated or you press the Start key, scanning of the original will start. Release the original when scanning starts.

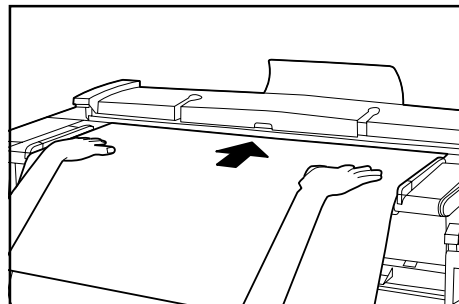

NOTE

- When using an original of which the leading edge is easily curled, the leading edge may be broken. Take care when using such original.
- The method of starting copying varies with the “⑫ Method of copy start” of the default setting. (Page 7-5)
- To scan an original with precision, open the original leading edge cover and place the original. See “● Setting the original with precision”.

● **When the original is curled:**

Open the original cover and set the original a little shifted from the position indicated by the original size indication toward the rear side (roller position at the rear side).

* When closing the original cover, grasp it with both hands and close it securely until it clicks.

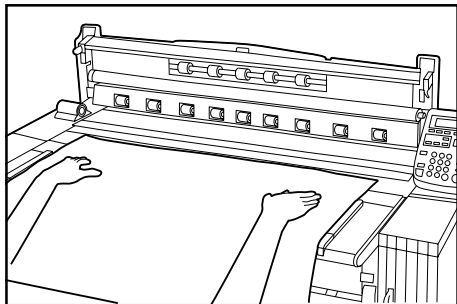

● **Setting the original with precision**

When copying a long original particularly, set the original as follows.

1 Adjust both the original guides to the original size indications on the original table.

2 Open the original leading edge cover.

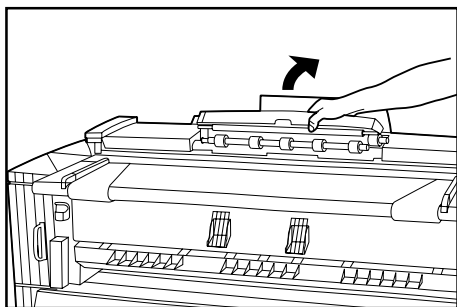

3 Place the original face down and put the leading edge of the original securely to the leading edge guide ①.

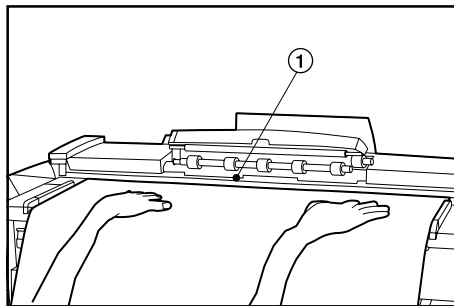

NOTE

- If the leading edge of the original is bulged at the leading edge guide, the original may be fed obliquely. Take care in setting the original.

4 Close the original leading edge cover. Press the Start key to start copying.

(5) How to Use the Carrier Sheet (option)

When using originals described in "Carrier sheet (option)", use this carrier sheet. (Page 3-1)

Carrier sheet sizes: 36" x 48", 24" x 36" (A0, A1, A2)

1 Open the carrier sheet by lifting up the transparent side and place the original face up between the two sheets. Set the original aligning it with the folding portion of the carrier sheet.

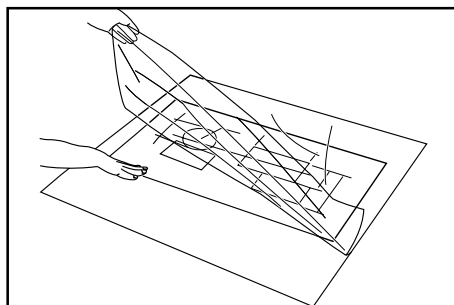

- 2** Set the original face down by placing the folding portion of the carrier sheet first.

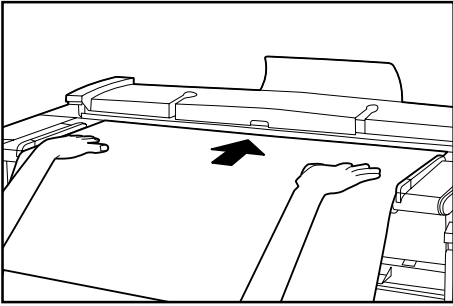

NOTE

- When using the carrier sheet, set the original tray horizontally. If the original tray is set horizontally, only one original can be stored.

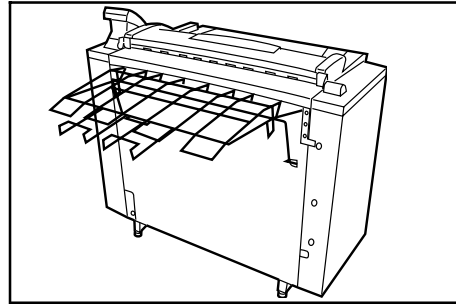

IMPORTANT

- When using the carrier sheet, set the "Select orig. eject direction" of the default setting (page 7-1) to "Discharge to back" ["Output to back"]. If "Discharge to front" ["Output to front"] is set, the original may be damaged.
- If synchronized cut is used in 100% copying, paper will be cut in length of the carrier sheet.

(6) How to Use the Original Tray (option)

This tray will store up to 20 originals of 36" x 48" [A1] size.

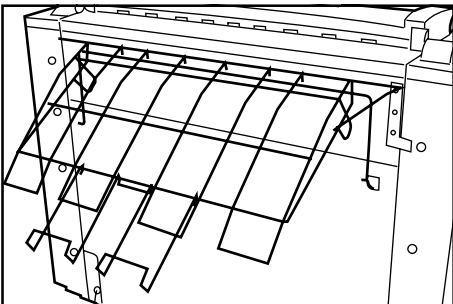

2. Paper

(1) Paper Types

Note the following restrictions on paper that can be used in this machine.

● Acceptable paper

1. Paper source 1 (option), paper source 2, and paper source 3
 - Paper roll width: 17" to 36" [210 to 920 mm]
 - Paper roll outer diameter: 6 3/4" [180 mm] or less
 - Paper roll inner diameter: 3" [76 mm (75.2 to 77.2 mm)]
 - Acceptable paper roll types
 - Plain paper (64 to 80 g/m²)
 - Vellum
 - Film
2. Bypass
 - Paper sizes (standard paper): 8 1/2" x 11" to 36" x 48" [A4 portrait to A0]
 - Paper width: 17" to 36" [210 to 920 mm]
 - Paper length: 11" to 48" [297 to 1189 mm]
 - Acceptable paper materials
 - Plain paper (64 to 80 g/m²)
 - Vellum
 - Film

● Unacceptable paper

- Paper other than the paper described in "● Acceptable paper"
- Paper with staples, etc.
- If paper is wrinkled, folded or broken, pull the paper roll until the problem disappears and cut the paper before using it.

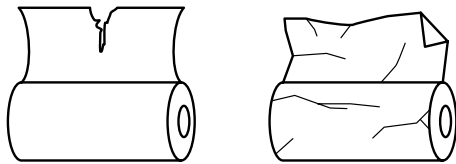

● Automatic paper width detection

If the paper roll that has been set is of a standard size, the paper width will be automatically detected. The following sizes can be detected.

Metric machine	Inch machine
<A sizes>	<Architecture>
A0: 841 mm	36"
A1: 594 mm	24"
A2: 420 mm	18"
A3: 297 mm	14"
A4: 210 mm	<Engineering>
<B sizes>	34"
B1: 728 mm	22"
B2: 515 mm	17"
B3: 364 mm	11"
B4: 257 mm	

NOTE

- Automatic detection will not function for the bypass.
- Paper width of non-standard sizes can be registered. See "① Paper width adjustment" of the default setting. (Page 7-1)
- For switching of standard size (architecture/engineering [A sizes/ B sizes]), select in "⑬ Standard size set" of the default setting. (Page 7-3)

● Storage of paper

If the machine is not used for an extended period time, remove the paper roll and return it to its original package and reseal it.

IMPORTANT

- Vellum
 - Since vellum is very susceptible to environment, when it is not used, put it in a plastic bag and seal it.
- When using vellum at a high humidity or at a low temperature, vellum will become fragile, resulting in wrinkles of copies or missing of images. If images are not properly copied, perform the following procedure.
 - * When using cut vellum:
 - Change the orientation of paper (portrait or landscape).
 - * When using vellum roll:
 - Pull out the paper roll by length of approximately one turn and cut the paper before using it.
- When using paper roll with adhesive substance, remove the adhesive substance or pull out the paper roll until the attached adhesive substance is not seen and then cut the paper before using it.

(2) How to Set Paper Roll

Use the same procedure when replacing paper roll.

IMPORTANT

- When replacing paper roll, turn the flanges on both sides to rewind the paper.

1 Open the front cover until it locks.

2 Grasp the roll unit handles **(A)** to release the lock and pull out the roll unit until it stops.

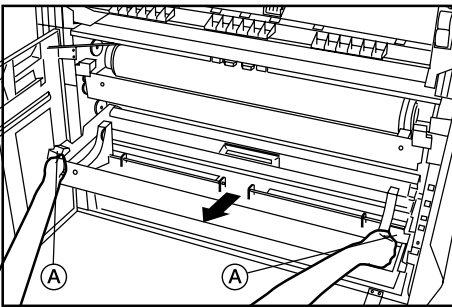

3 Lift up the release levers **(1)** and adjust flange guides **(2)** on both sides to the paper size.

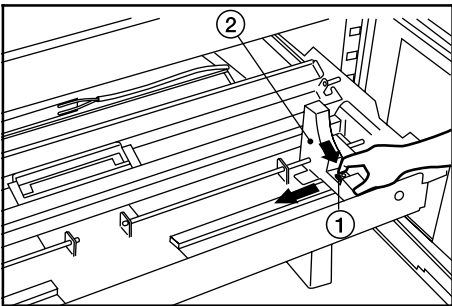

4 Insert a supplied flange into the core of new roll.

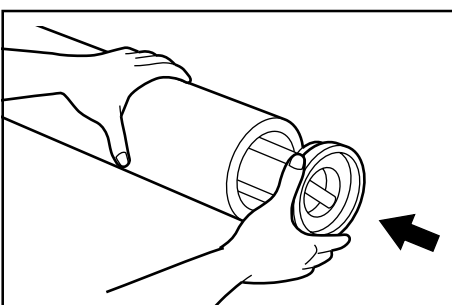

5 Grasp the flange and turn its lever in the direction indicated by the arrow. The flange will be secured to the paper roll.

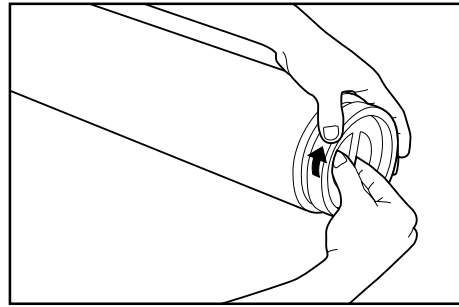

6 Secure the other flange to the paper roll similarly.

7 Set the paper roll in the roll unit by aligning it with the flange guides **(2)**. After setting the paper roll, check that the flange tray is not moved.

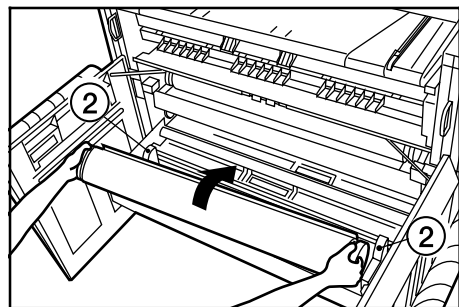

8 Grasp both paper roll insertion latches **(3)** and open the paper roll insertion cover **(4)**.

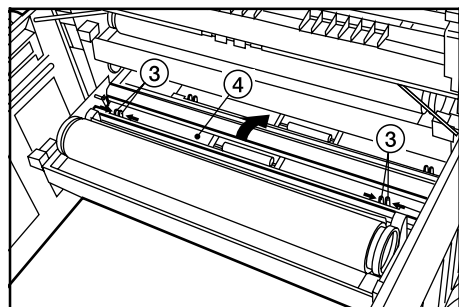

- 9** Insert the leading edge of the paper roll under the transport guide plate and put out the edge from the guide plate by approximately 1/2" [10 mm] as shown in the illustration.

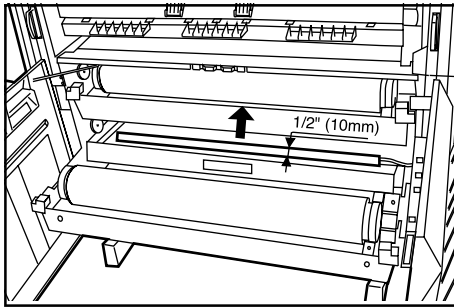

NOTE

- If the leading edge of paper roll is folded or broken, cut the edge using a cutter or the like.

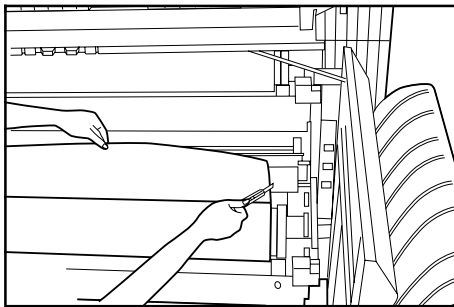

- 10** Grasp the paper roll insertion latches and close the paper roll insertion cover securely.

IMPORTANT

- If the paper roll that has been set is slackened, grasp the flange and wind the paper roll to remove the slack. If not, paper may be fed obliquely.

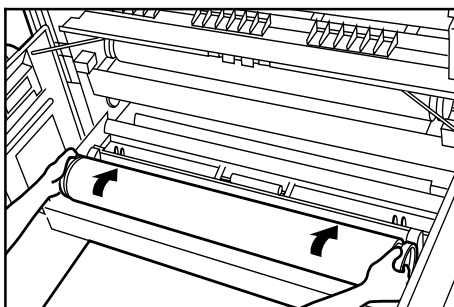

- 11** Insert the roll unit securely into the main body of the machine.

- 12** Close the front cover.

- 13** To align the leading edge of the paper roll, press the Paper Cut key. The leading edge of the paper roll will be ejected from the copy eject slot.

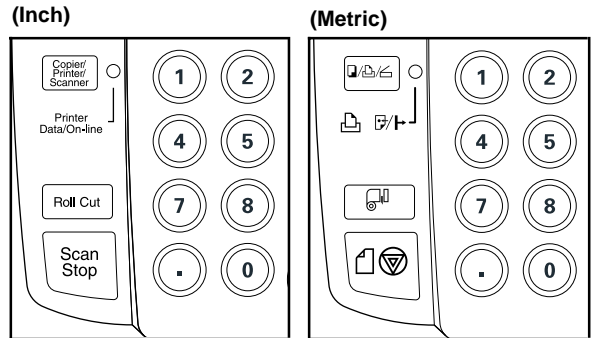

NOTE

- Paper is normally cut in length of 11" [279 mm]. If the temperature in the machine is lower than 15°C, however, vellum will be cut in length of 31" [800 mm].

(3) Dew prevention heater

If the humidity is high (more than 70%RH) or drastic temperature change occurs, turn on (I) the dew prevention heater switch when using the machine. Even if the main power switch is off(O), the dew prevention heater switch can be on (I).

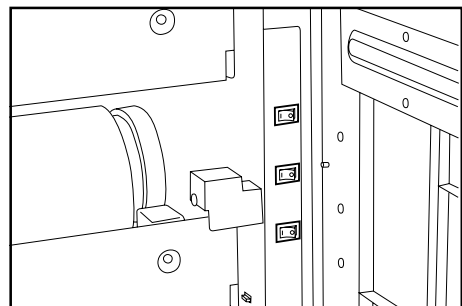

IMPORTANT

- When using vellum or film, be sure to turn off(O) the dew prevention heater switch. If not, paper may be wrinkled or curled.

(4) How to Use the Copy Tray Support Plate

Set the copy tray support plate based on the paper to be used for copying.

- 1** Incline a copy tray support plate up and slide it to the size indication on the size label of the copy tray.

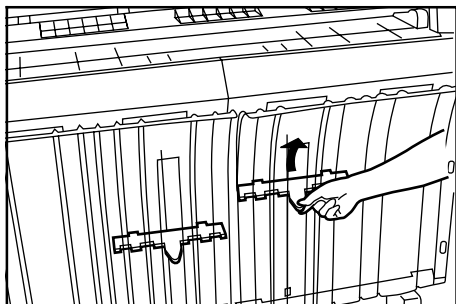

- 2** After setting the copy tray support plate to the desired size, return it to a horizontal state.

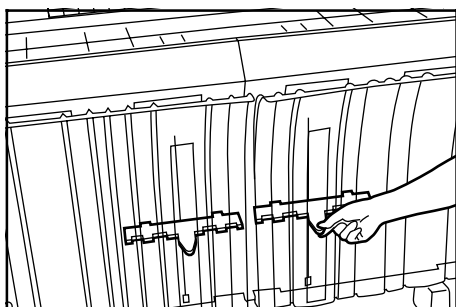

- 3** Set the other copy tray support plate to the same height in the same procedure.
Depending on the paper to be used and the environment, the support plate may not be contained at the position of the size label. In this case, adjust the position of the copy tray support plate upward or downward.

CHAPTER 4 BASIC COPYING

1. Before starting copying

(1) Initial state

When the main power switch of this machine is turned on (I) (and warm up is complete, the machine is ready to copy. This state is called initial state and the screen displayed in this state is called basic screen.

The machine also enters the initial state when the auto clear function is activated or the Reset key is pressed.

Be sure to ensure that the machine is in the initial state before copying.

When the auto clear function is activated, however, the exposure display will not return to the initial setting.

(Inch)

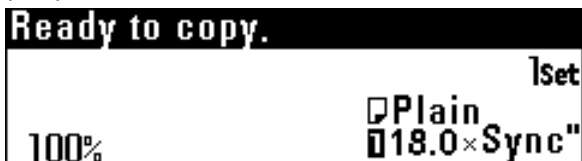

(Metric)

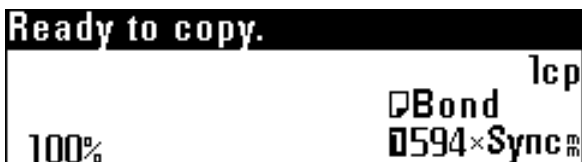

(2) When the Energy Saver indicator is lit

When the Energy Saver indicator is lit and other indicators are off on the operation panel, the machine is in the energy saver mode. When the Energy Saver key is pressed, warm up will start.

(Inch)

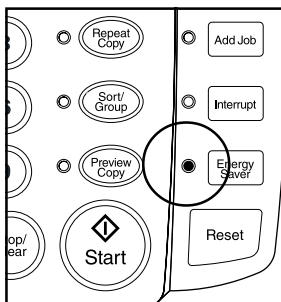

(Metric)

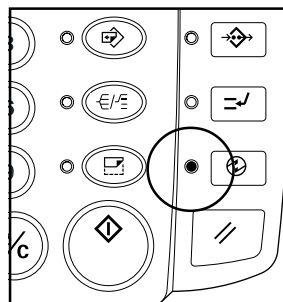

(3) When using a key counter (option)

If the message "Insert key counter." appears, a key counter must be set in this machine.

Insert the key counter all the way into the key counter insert slot located on the right of the main body.

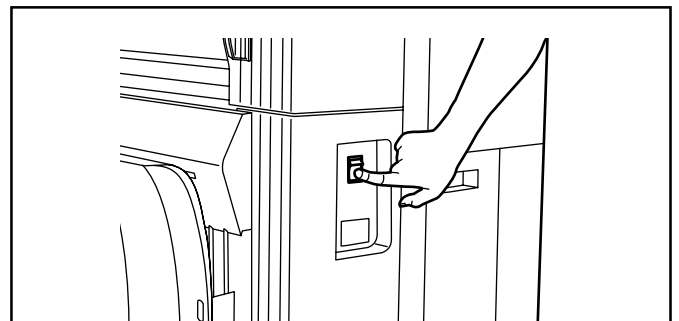
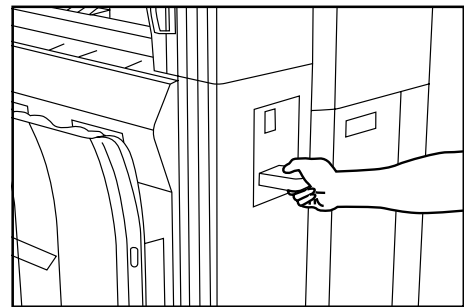

CAUTION

If the copier will not be used for a short period of time (overnight, etc.), turn the main switch OFF (O). If it will not be used for an extended period of time (vacations, etc.), remove the power plug from the outlet for safety purposes during the time the copier is not in use.

2. Basic Copying

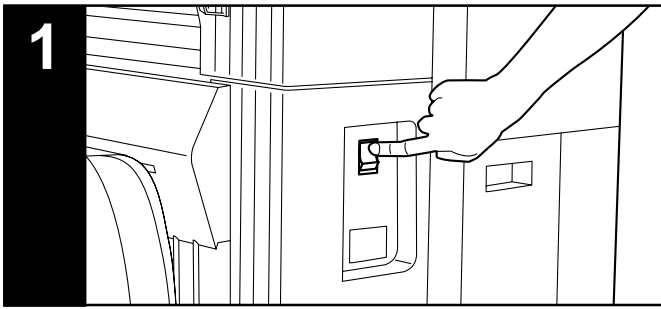

1. Turn the main power switch on.

Turn the main power switch on (1). The machine will warm up for approximately 360 seconds.

When the message "Ready to scan." appears in the message display, scanning of originals or copy function setting can be performed.

When "Ready to copy." appears, copying can be performed.

* When turning on and off the main power switch repeatedly, be sure to turn on and off at an interval of more than 1 second. If the interval is less than 1 second, the machine may not start normally.

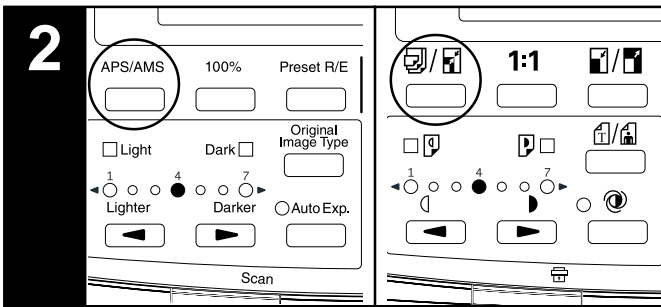

2. Select the desired copy mode. (Page 4-4)

Press the APS/AMS key to select the APS mode or the AMS mode.

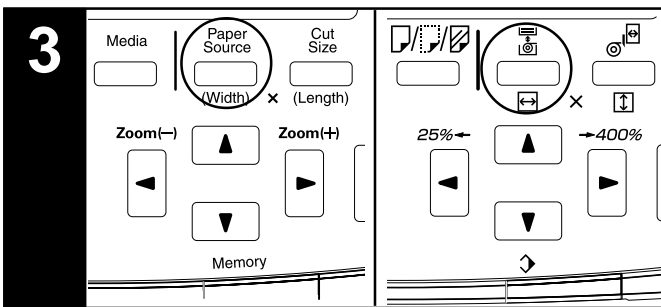

3. Select the desired paper source.

Press the Paper Source key to select the desired paper source.

A number indicating a paper source will be displayed in the message display.

When the bypass is selected, the margin copy, border erase, APS, and AMS functions cannot be used.

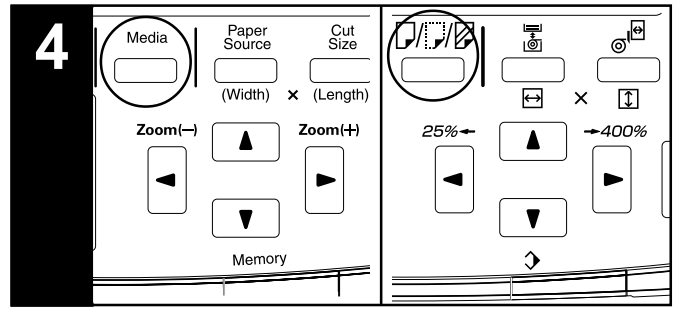

4. Select the paper material. (Page 4-5)

Press the Media key to select the desired paper material. The paper material can be selected from "Plain", "Vellum", "Film", and "Custom".

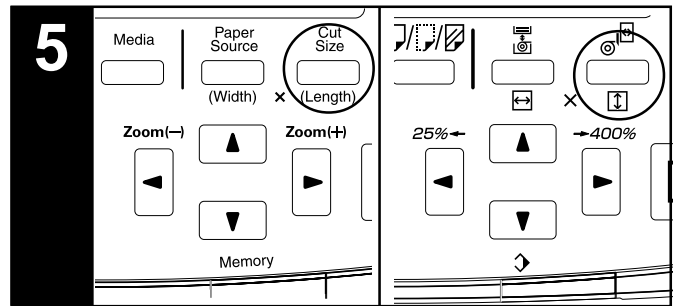

5. Select the cut length. (Page 4-6)

Press the Cut Size key to select the desired cut method. The method can be selected from "Synchronized cut" ["Synchronized"], "Standard cut" ["Standard size"], and "# keys".

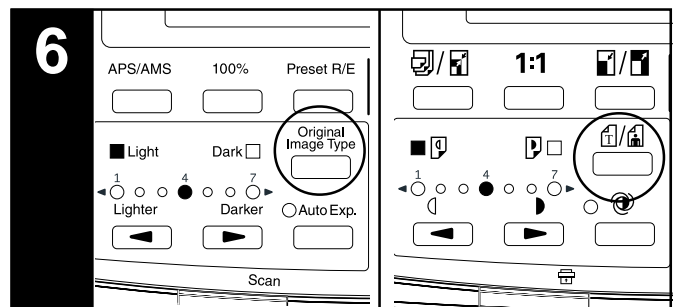

6. Select the original contrast.

Press the Original Image Type key. Press the top ▲▼ key to select the type of the original. To return to the basic screen, press the OK key.

"Normal original": Standard originals such as drawings and newspapers. When using the carrier sheet, select this mode.

"Text": Select this mode when using originals containing both text and line drawing.

"Photo": Select this mode when using originals such as photos and posters.

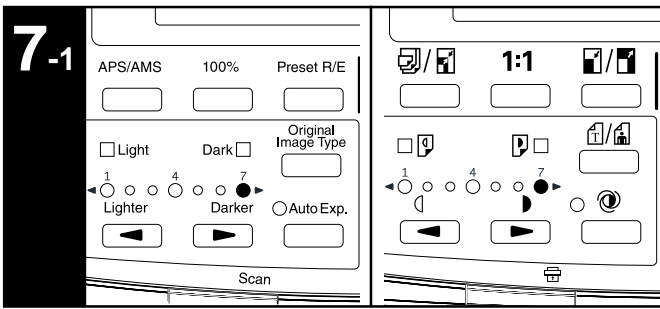

7-1. Select the copy contrast.

When adjusting manually the copy contrast, press the copy contrast keys. Right copy contrast indicators indicate darker exposure levels. To make the copy contrast darker than “7” when “Normal original” has been selected, press the right copy contrast key. The Dark indicator will light up and “1” will light up. The exposure level can be darkened up to “7”.

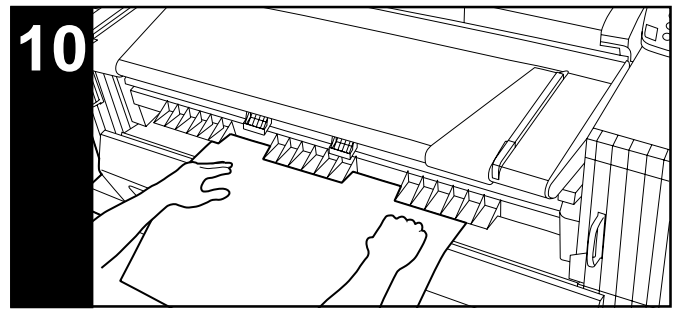

10. Set the paper. (Page 4-8)

Set the paper only when using the bypass.

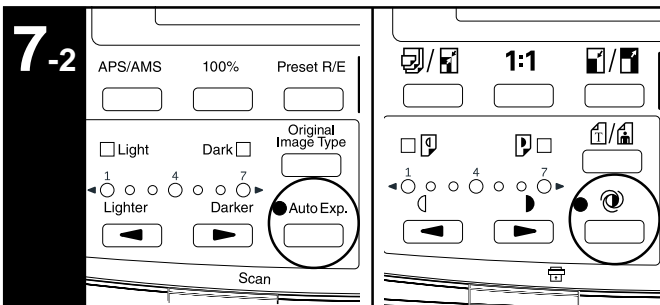

7-2. When adjusting the copy contrast automatically, press the Auto Exp. key. The Auto Exp. indicator will light up.

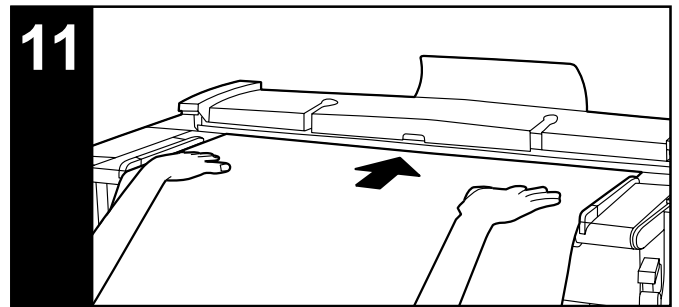

11. Set the original. (Page 3-2)

When the original is set, copying will start automatically.

* Depending on the setting of “12 Method copy start” of the default setting, the Start key must be pressed for starting copying. (Page 7-5)

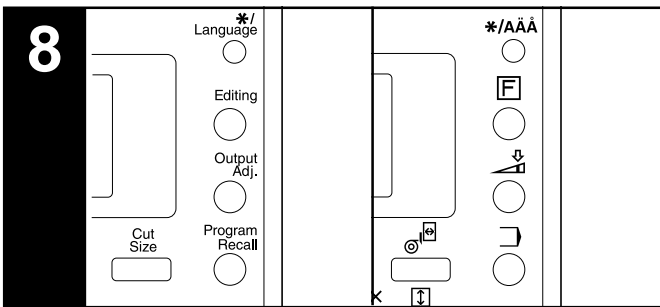

8. Set the desired functions.

Set the desired functions referring to the description of each function.

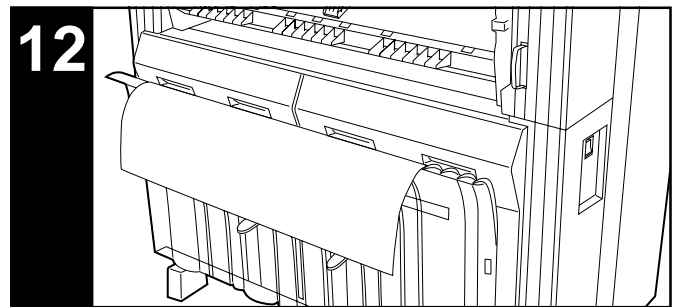

12. After copying

The copy will be ejected to the copy tray.

The capacity of the copy tray: 20 sheets (24" x 36", A1

[room temperature and humidity])

15 sheets (36" x 48", A0

[room temperature and humidity])

1 sheet (other sizes, Vellum and Film)

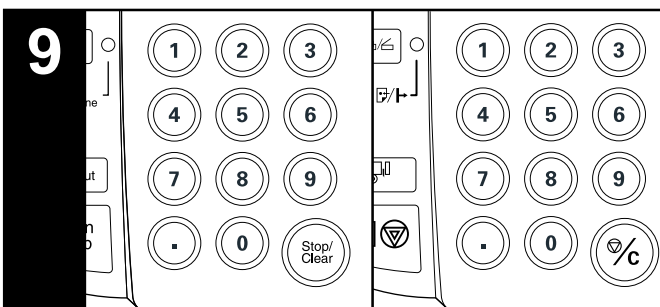

9. Set the number of copies to be made.

Use the numeric keys to enter the desired number of copies from 1 to 99. The initial setting of the number of copies is 1.

3. Copy Modes

This machine provides three copy modes: "APS", "AMS", and "Manual". The copy mode selected in the initial state can be changed using "⑩ Auto select set" of the default setting. (Page 7-5)

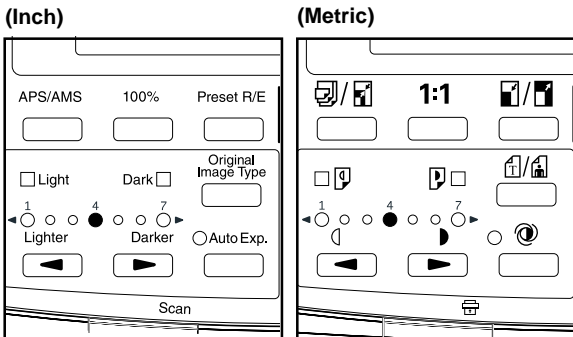

(1) APS mode

When an original is set, a paper source of the size specified based on the original size and the magnification ratio will be automatically selected. To select the APS mode, press the APS/AMS key to display "APS".

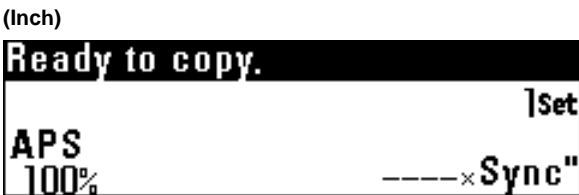

NOTE

- The bypass cannot be selected automatically.
- To press the Paper Source key to enter the AMS mode when the APS mode has been set, set the "AMS mode" of the default setting to "ON". (Page 7-5)
- If "⑩ Auto rotation mode" of the default setting has been set to "ON", when the orientation of the original is different from that of the paper, the image will be automatically rotated counterclockwise by 90 degrees and copied.

(2) AMS mode

When an original is set, the magnification ratio will be automatically set based on the selected paper size. To select the AMS mode, press the APS/AMS key to display "AMS".

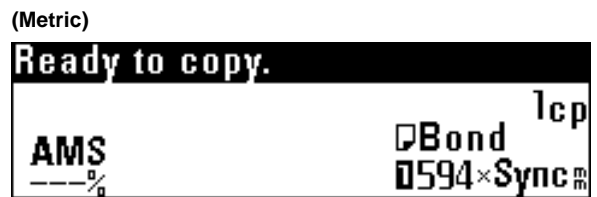
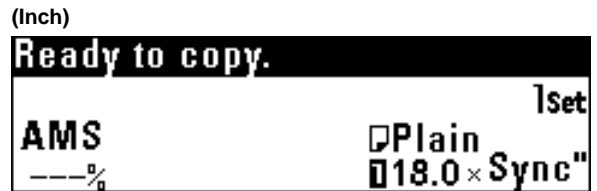

NOTE

- If the bypass is selected, the magnification ratio will be 100%.
- If "⑩ Auto rotation mode" of the default setting has been set to "OFF", the magnification ratio will be automatically set based on the width of the original and the width of the selected paper size.
- If "⑩ Auto rotation mode" of the default setting has set been to "ON", when the orientation of the original is different from that of the paper, the image will be automatically rotated counterclockwise by 90 degrees and copied.

(3) Manual mode

A paper source and a magnification ratio are selected manually for copying.

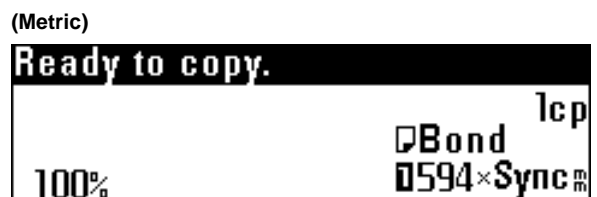
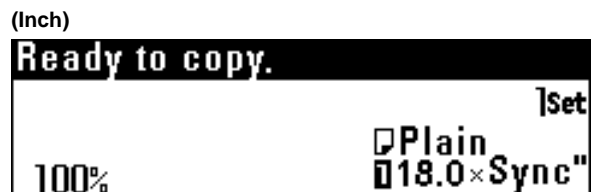

4. Paper Material Selection

If the Media key is pressed, the paper material to be used can be selected from "Plain" ["Bond paper"], "Vellum", "Film", and "Custom". If the paper material is selected, fixing temperature and copy size will be automatically adjusted.

If "Custom" is selected, paper material, fixing temperature, and copy size that have been set by using "⑫ Custom paper adj." ["Custom paper material adj.,"] of the default setting will be selected. (Page 7-3) If "⑫ Paper working" of the default setting is set to "ON", the paper material installed in each paper source can be registered. If the Paper Source key is pressed to select a paper source, the paper material setting will be automatically changed. See "⑫ Paper working" and "⑬ Paper material adjustment" of the default setting. (Page 7-1)

- 1 Press the Media key.

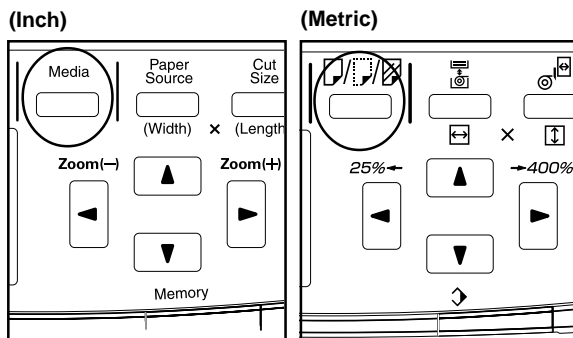

- 2 Press the ▼ or ▲ key to select the paper material to be used. Select the material from "Plain" ["Bond paper"], "Vellum", "Film", and "Custom".

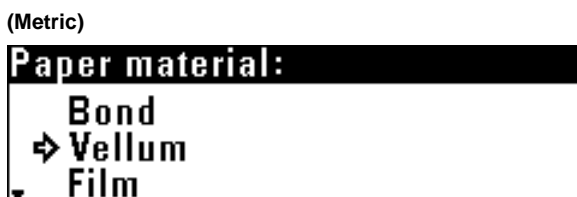
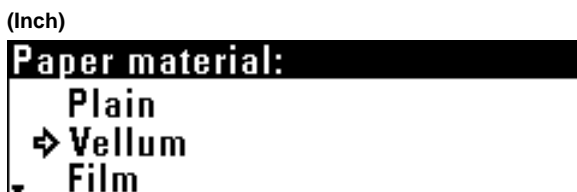

- 3 Press the OK key.

- 4 Check that the selected paper material is displayed in the message display. When the paper material is changed, wait until the fixing temperature is stabilized. Scanning of an original, however, can be performed.

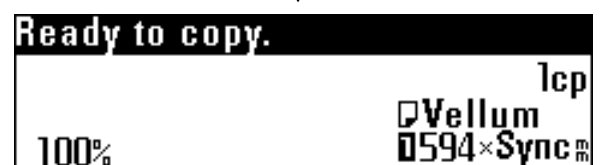
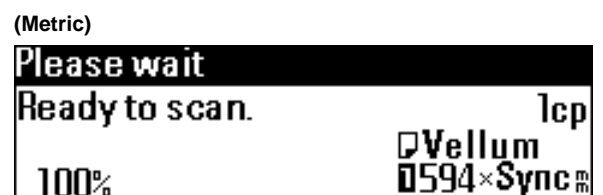
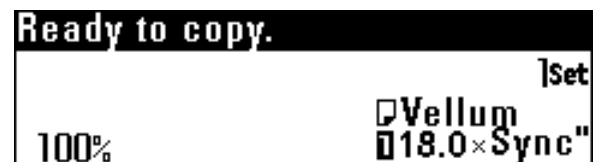
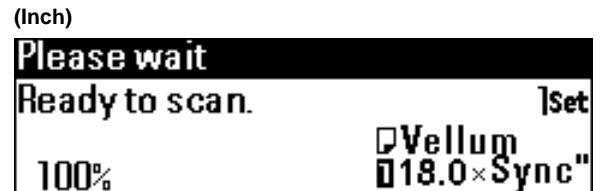

5. Paper Roll Cut Length Selection

(1) Synchronized cut

Paper is cut based on the length of the original and the magnification ratio.

The minimum cut length by synchronized cut is 11" [279 mm]. Even if the copy image length is less than 11" [279 mm] due to reduction, a blank area will be added in the trailing edge of the paper and paper will be cut in length of 11" [279 mm].

1 Press the Cut Size key.

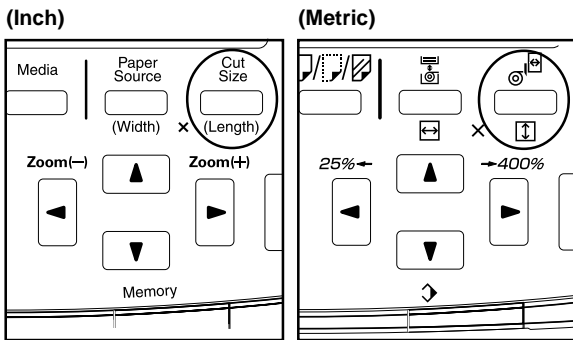

2 Ensure that "Synchronized cut" ["Synchronized"] is selected.

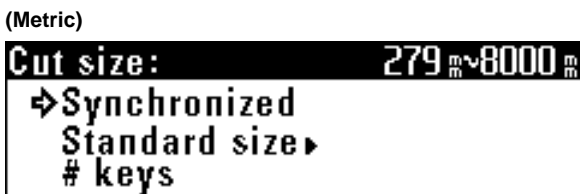
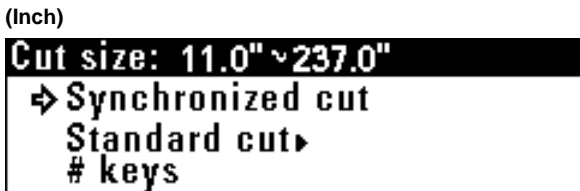

3 Press the OK key.
The machine will return to the basic screen.

(2) Standard cut

Paper is cut in length of standard size or in a length that has been registered. The following lengths can be selected.

● Cut size (inch machine)

(Architecture)	(Engineering)
48"	44"
36"	34"
24"	22"
18"	17"
12"	11"
User 1 (40")	User 1 (40")
User 2 (80")	User 2 (80")

● Cut size (metric machine)

(A sizes)	(B sizes)
1189 mm	1030 mm
841 mm	728 mm
594 mm	515 mm
420 mm	364 mm
297 mm	User 1 (1000 mm at default setting)
User 1 (1000 mm at default setting)	User 2 (2000 mm at default setting)
User 2 (2000 mm at default setting)	

* Architecture or Engineering for inch machine and A sizes or B sizes for metric machine can be selected using "③ Standard size setting". (Page 7-3)

For user 1 and user 2, any cut size can be registered. See "④ Cut size register". (Page 7-4)

1 Press the Cut Size key.

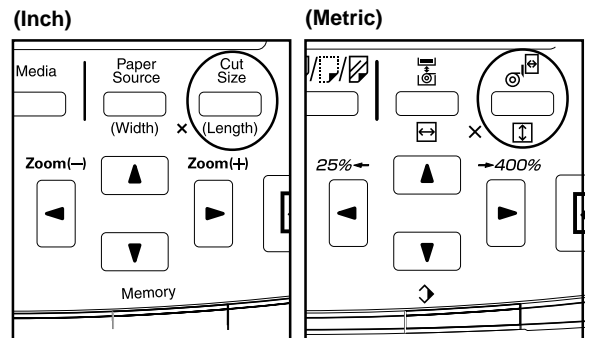

- Press the ▼ or ▲ key to select "Standard cut" ["Standard sizes"].

(Inch)

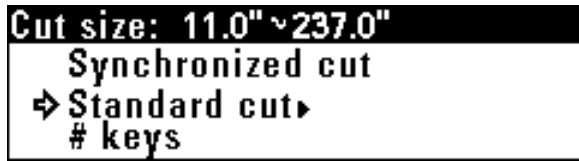

(Metric)



- Press the OK key.

- Press the ▼ or ▲ key to select the desired cut length.

(Inch)

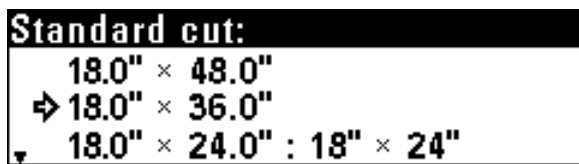

(Metric)



- Press the OK key. The machine will return to the basic screen.

(3) Numeric key input

Enter the desired cut size using the numeric keys. For paper in the bypass table, cut cannot be selected.

- Press the Cut Size key.

(Inch)

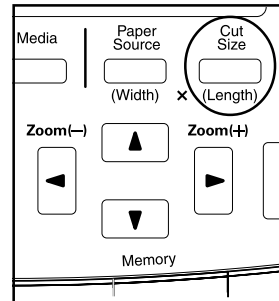

(Metric)

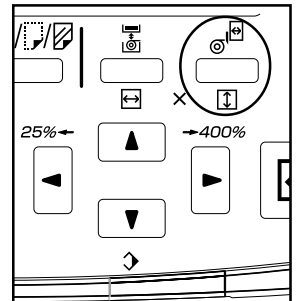

- Press the ▼ or ▲ key to select "# keys".

(Inch)

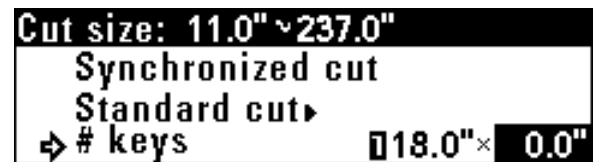

(Metric)



- Use the numeric keys to enter the desired cut size. The cut size that can be entered is 11" to 237" [279 to 6,000 mm].

(Inch)

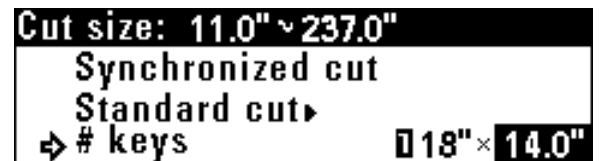

(Metric)



NOTE

The cut size can be changed by using the numeric keys after pressing the Cut Size key.

- Press the OK key. The machine will return to the basic screen. Confirm that the selected size is displayed.

6. Bypass Copy

When copying through the bypass slot, perform the following procedure.

NOTE

- Only one sheet of paper can be set in the bypass table.
- When using curled paper, stretch the paper. If curling is not cleared, place the paper with curled surface up.
- When using the bypass, the margin copy, border erase, APS, and AMS functions cannot be used.

1 Set copy conditions such as the number of copies.

2 Press the Paper Source key to select "Bypass".

3 Adjust the bypass guides to the paper size indications on both sides of the bypass table.

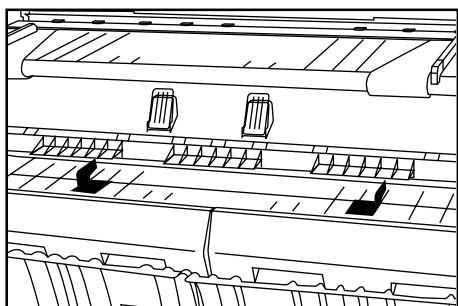

4 Set the paper face down all the way into the feed slot aligning with the paper size indication. When placing paper in the bypass table, set the paper quickly all the way into the feed slot. When paper is fed, release the paper. If the paper is not set properly, a paper jam may be detected. If paper is set obliquely, pull the paper out and then set it again.

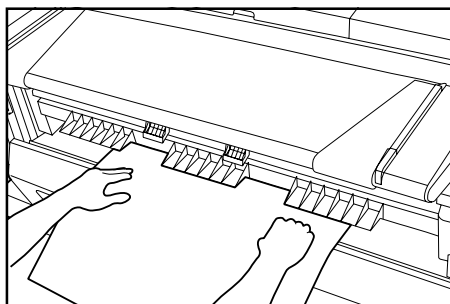

5 Set the original to start copying.

6 When the message "Add paper in bypass." ["Add paper on stack bypass."] appears, set the next paper in the bypass table. Copying will start. Set the required number of sheets of paper one sheet at a time for copying.

7. Canceling Copying

The method for canceling copying varies with the situation.
Use the proper procedure in accordance with the situation.

Situation	Operation
To stop immediately scanning:	Press the Scan Stop key. Scanning of original will stop. Open the original cover and remove the original.
To stop scanning of original in the sort copy mode:	Press the Stop/Clear key.
To stop immediately output of paper while the copy is being output: (to cut the paper at some midpoint)	Press the Roll Cut key.
To stop output of paper while the copy is being output: (to stop after ejecting the paper in progress)	Press the Stop/Clear key.
To cancel a reserved job:	Press the Add Job key for more than two seconds. A screen for deleting reserved jobs will appear. Delete the desired job referring to "2. Canceling job reserve". (Page 6-8)
To cancel reserved repeat copy:	Press the Repeat Copy key.

CHAPTER 5 FUNCTIONAL COPYING

1. Zoom mode

The magnification ratio can be set by pressing the ◀ or ▶ key. The magnification ratio can be set to from 25% to 400% in 1% or 0.1% increments. The method for setting the magnification ratio is described below.

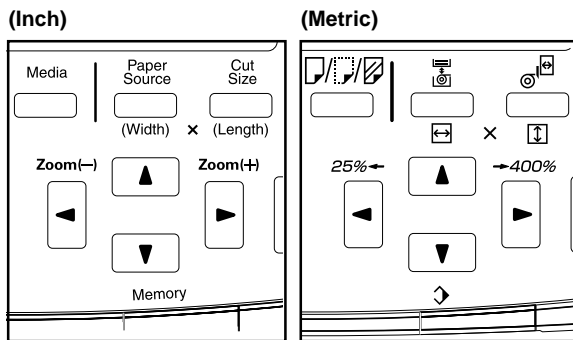

NOTE

- To switch the increment of the magnification ratio between 1% and 0.1%, see “② Zoom step” [“Zoom steps”] of the default setting. (Page 7-4)
- If “APS” has been set, when the magnification ratio is changed, the paper size will be automatically changed.
- If the magnification ratio increment is set to 1%, the fractional portion of the number will be dropped.
- The minimum cut length of paper is 11" [279 mm]. If reduction and synchronized cut are set and the calculated paper length is less than 11" [279 mm], paper will be cut in length of 11" [279 mm] and a blank area will be added in the trailing edge of the paper.

(1) Standard zoom

The magnification ratio to be used is directly selected for reduction or enlargement.

For the magnification ratios that can be selected, see “● List of magnification ratios”.

● List of magnification ratios (inch machine)

Magnification ratio display		Display
(0.1%)	(1%)	Architecture
400.0%	400%	9"x12"→36"x48"
266.6%	266%	12"x18"→36"x48", 9"x12"→24"x36"
200.0%	200%	18"x24"→36"x48", 12"x18"→24"x36", 9"x12"→18"x24"
133.3%	133%	24"x36"→36"x48", 18"x24"→24"x36", 12"x18"→18"x24", (9"x12"→12"x18")
66.6%	66%	36"x48"→24"x36", 24"x36"→18"x24", 18"x24"→12"x18", (12"x18"→9"x12")
50.0%	50%	36"x48"→18"x24", 24"x36"→12"x18", 18"x24"→9"x12"
33.3%	33%	36"x48"→12"x18", 24"x36"→9"x12"
25.0%	25%	36"x48"→9"x12"

Magnification ratio display		Display
(0.1%)	(1%)	Engineer
400.0%	400%	8.5"x11"→34"x44"
258.8%	258%	11"x17"→34"x44", 8.5"x11"→22"x34"
200.0%	200%	17"x22"→34"x44", 11"x17"→22"x34", 8.5"x11"→17"x22"
129.4%	129%	22"x34"→34"x44", 17"x22"→22"x34", 11"x17"→17"x22", (8.5"x11"→11"x17")
64.7%	64%	34"x44"→22"x34", 22"x34"→17"x22", 17"x22"→11"x17", (11"x17"→8.5"x11")
50.0%	50%	34"x44"→17"x22", 22"x34"→11"x17", 17"x22"→8.5"x11"
32.3%	32%	34"x44"→11"x17", 22"x34"→8.5"x11"
25.0%	25%	34"x44"→8.5"x11"

Sizes in () will not be displayed.

● List of magnification ratios (metric machine)

Magnification ratio display		Size display	
(0.1%)	(1%)	A sizes	B sizes
400.0%	400%	A4→A0	
282.9%	282%	A3→A0, A4→A1	B4→B1
200.0%	200%	A2→A0, A3→A1, A4→A2	B3→B1, B4→B2
141.4%	141%	A1→A0, A2→A1, A3→A2	B2→B1, B3→B2, B4→B3
70.6%	70%	A0→A1, A1→A2, A2→A3	B1→B2, B2→B3, B3→B4
50.0%	50%	A0→A2, A1→A3, A2→A4	B1→B3, B2→B4
35.2%	35%	A0→A3, A1→A4	B1→B4
25.0%	25%	A0→A4	

1 Press the Preset R/E key.

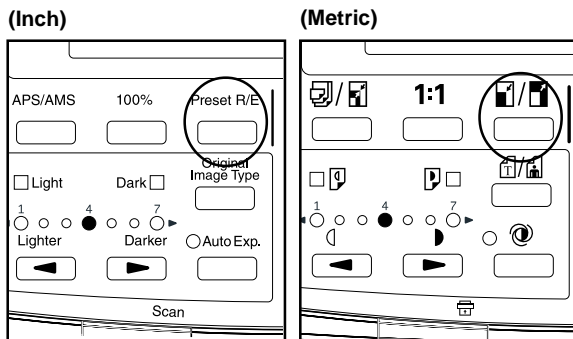

4 Press the ▼ or ▲ key to select the desired magnification ratio.

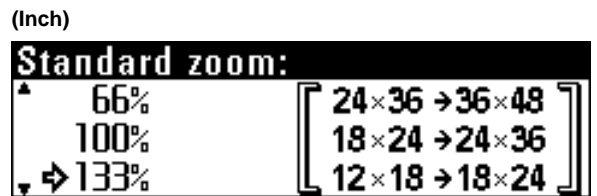

2 Ensure that "Standard zoom" is selected.



3 Press the OK key.

5 Press the OK key. The machine will return to the basic screen. The selected magnification ratio will be displayed.

(2) User setting zoom

Any magnification ratio that has been registered to user 1 to user 5 is selected for copying.

NOTE

- For registering magnification ratios to user 1 to user 5, see “③ Zoom register” of the default setting to register any magnification ratio. (Page 7-4)

1 Press the Preset R/E key.

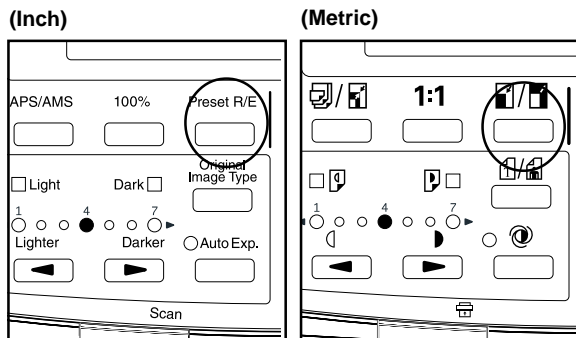

2 Press the ▼ or ▲ key to select “User Setting Zoom”.



3 Press the OK key.

4 Press the ▼ or ▲ key to select the desired magnification ratio.

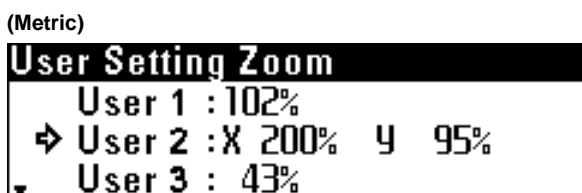
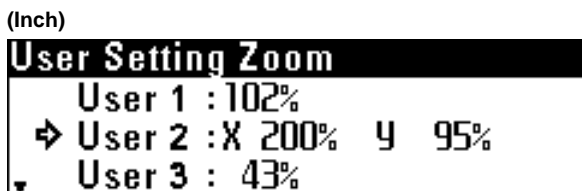

5 Press the OK key.
The machine will return to the basic screen. The selected magnification ratio will be displayed.

(3) XY zoom

Separate magnification ratios can be set for lengthwise and widthwise enlargement/reduction of copies.

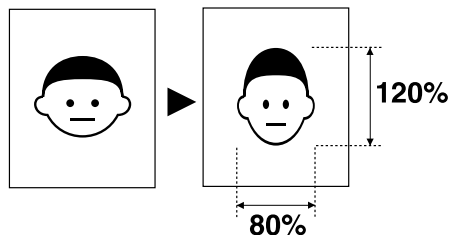

1 Press the Preset R/E key.

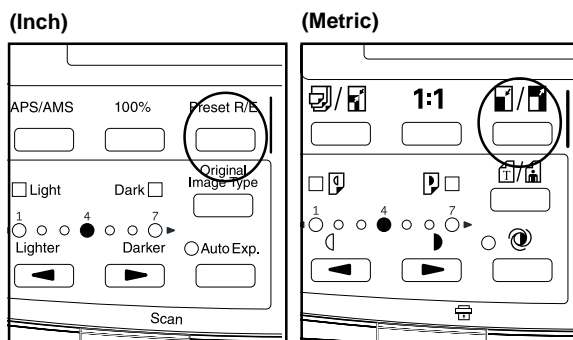

2 Press the ▼ or ▲ key to select “XY zoom”.



3 Press the OK key.

- 4** Press the ◀ or ▶ key or the numeric keys to enter the desired magnification ratio for the widthwise (X) direction.

(Inch)



(Metric)



- 5** Press the ▼ key.

- 6** Press the ▼ or ▲ key or the numeric keys to enter the magnification ratio for the lengthwise (Y) direction.

(Inch)



(Metric)



- 7** Press the OK key.
The machine will return to the basic screen. The selected magnification ratios will be displayed. The magnification ratios can be changed by using the ◀, ▶, ▼ and ▲ keys.

(4) Zoom

The magnification ratio can be entered by using the ◀ or ▶ key or the numeric keys.

- 1** Press the Preset R/E key.

(Inch)

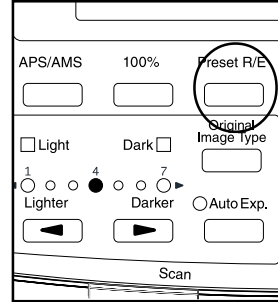

(Metric)

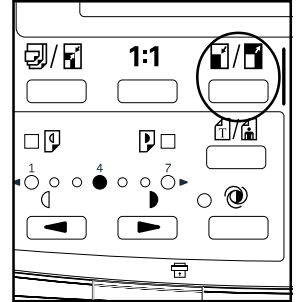

- 2** Press the ▼ or ▲ key to select “#/Zoom keys”.

(Inch)



(Metric)



- 3** Use the ◀ or ▶ key or the numeric keys to change the magnification ratio (25% to 400%).

- 4** Press the OK key. The machine will return to the basic screen. The magnification ratio can also be changed by using the ◀ or ▶ key.

NOTE

If the Preset R/E key is pressed and then the ◀ or ▶ key or a numeric key is pressed, the “#/Zoom keys” mode will be immediately selected.

- ① Press the Preset R/E key.
- ② Press the ◀ or ▶ key or the numeric keys to set the desired magnification ratio.

2. Editing Functions

(1) Image shift

Copy images can be shifted on paper to the top, bottom, right or left. The image shift length is 8" [200 mm] at the maximum and can be changed in 0.1" [1 mm] increments. If synchronized cut is selected in 100% copying, the original length will be equal to the paper length.

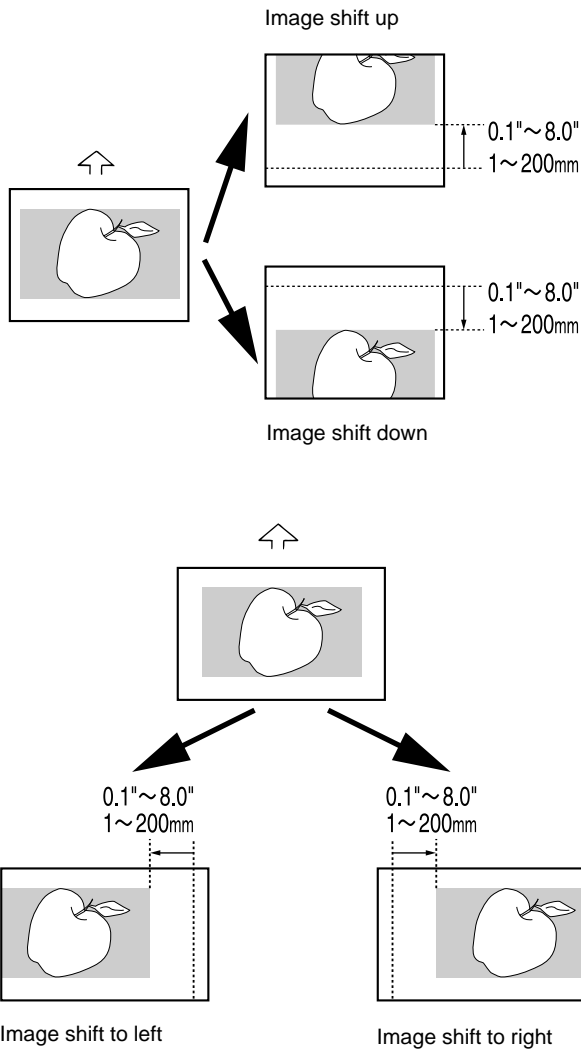

NOTE

• The default value for shift up, shift down, shift to left, and shift to right can be set respectively by using "Ⓜ Default of edit. Function" of the default setting. (Page 7-7)

1 Press the Editing key.

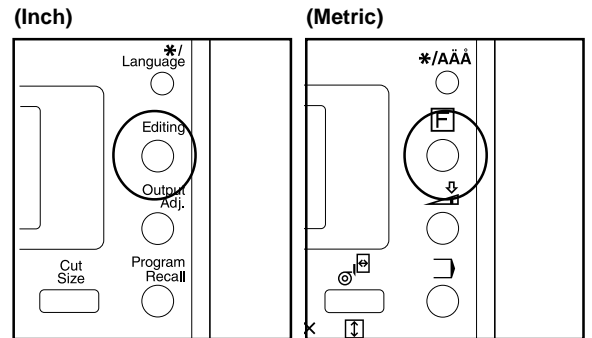

2 Press the ▼ or ▲ key to select "Shift".

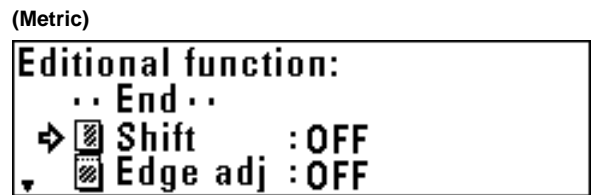
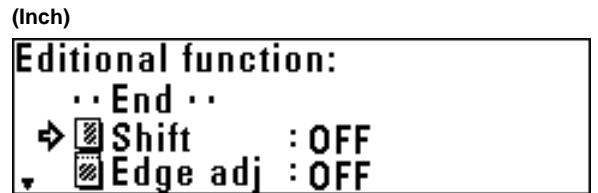

3 Press the OK key.
 • To shift the image up or down, proceed to the next step.
 • To shift the image to the right or left, proceed to step 10.
 • To cancel all image shift settings, proceed to step 17.

> Setting of shift up or down

4 Press the ▼ or ▲ key to select "Up/Down".

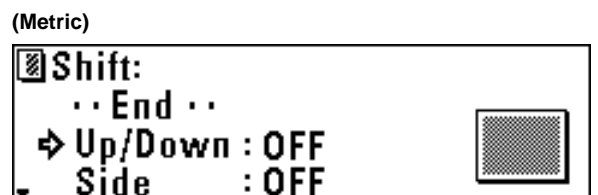
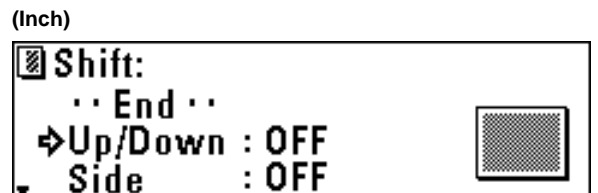

5 Press the OK key.

- 6** The shift direction and the shift amount will be displayed in the top line of the message display.
- To change the settings, press the ▼ or ▲ key to select "Change".
 - To accept the settings without change, ensure that "ON" is selected.

- 7** Press the OK key.
- If "Change" has been selected, proceed to the next step.
 - If "ON" has been selected, proceed to step 10.

- 8** Press the ▼ or ▲ key to select up or down and change the shift amount using the numeric keys.

(Inch)



(Metric)



- 9** Press the OK key.

> Setting of shift to right or left

- 10** To shift the image to the right or left, press the ▼ or ▲ key to select "Side".
To complete the setting, ensure that "End" is selected and press the OK key. The machine will return to the basic screen.

(Inch)

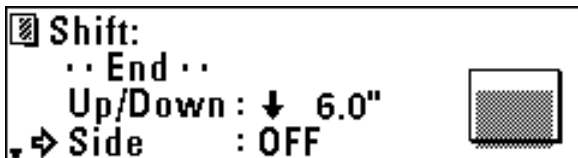

(Metric)

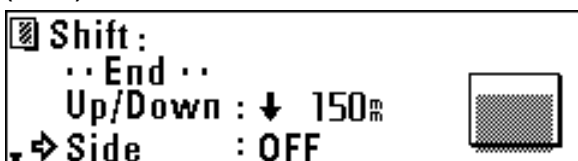

- 11** Press the OK key.

- 12** The shift direction and the shift amount will be displayed in the top line of the message display.
- To change the settings, press the ▼ or ▲ key to select "Change".
 - To accept the settings without change, ensure that "ON" is selected.

- 13** Press the OK key.
- If "Change" has been selected, proceed to the next step.
 - If "ON" has been selected, proceed to step 16.

- 14** Press the ▼ or ▲ key to select right or left and change the shift amount using the numeric keys.

(Inch)

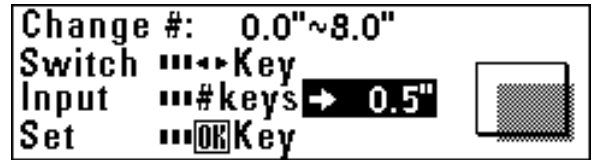

(Metric)



- 15** Press the OK key.

- 16** To complete the setting, ensure that "End" is selected and press the OK key. The machine will return to the basic screen.

> Canceling all image shift settings

- 17** To cancel all image shift settings, press the ▼ or ▲ key to select "Cancel" and press the OK key. The machine will return to the basic screen.

(2) Margin copy

● Leading edge margin

A margin is made or cut at the leading edge (original insertion side) of the copies. The margin amount is 8" [200 mm] at the maximum in both cases and can be changed in 0.1" [1 mm] increments.

If the synchronized cut is selected in 100% copying and a leading margin is added, the paper length will be longer than the original length by the amount of the margin. If the margin of the leading edge is cut, the paper length will be shorter than the original length by the amount of the margin. The minimum paper cut length, however, is 11" [279 mm].

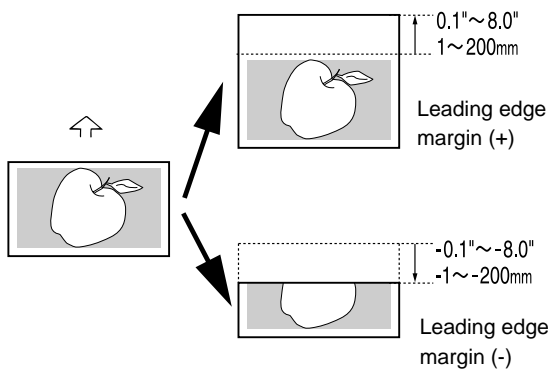

● Trailing edge margin

A margin is made or cut at the trailing edge (opposite of the original insertion side) of the copies. The margin amount is 8" [200 mm] at the maximum in both cases and can be changed in 0.1" [1 mm] increments.

If the synchronized cut is selected in 100% copying and a trailing margin is added, the paper length will be longer than the original length by the amount of the margin. If the margin of the trailing edge is cut, the paper length will be shorter than the original length by the amount of the margin. The minimum paper cut length, however, is 11" [279 mm].

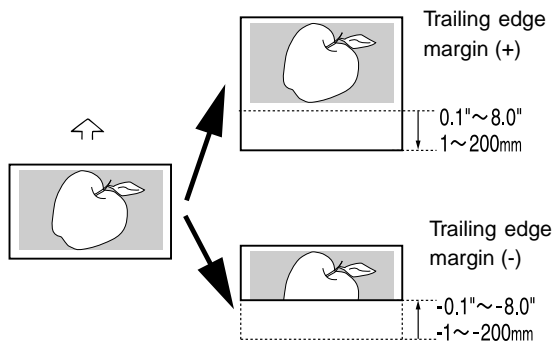

● Whole sheet print

If images cover the overall area of the original, part of copy images may be lost. If whole sheet print is specified, a margin of 0.4" [10 mm] is added to the leading and trailing edges respectively on the copy and the whole image will be copied without image loss.

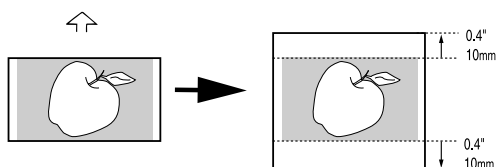

Whole sheet print

NOTE

- The default margin amount of the leading and trailing edges can be set respectively by using "Ⓣ Default of edit. Function" of the default setting. (Page 7-7)

1 Press the Editing key.

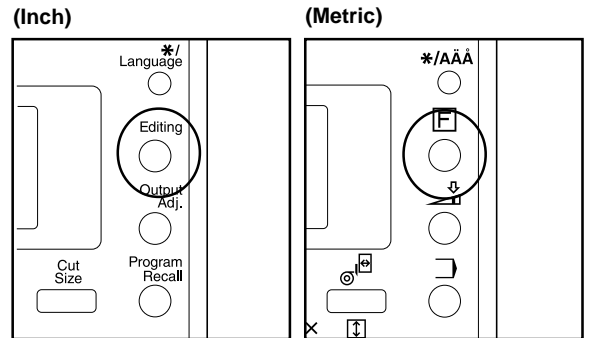

2 Press the ▼ or ▲ key to select "Edge adj".

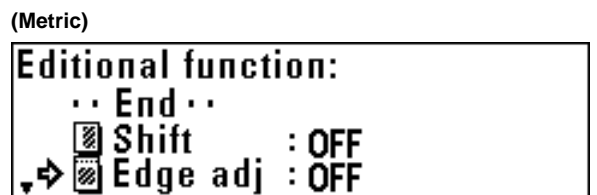
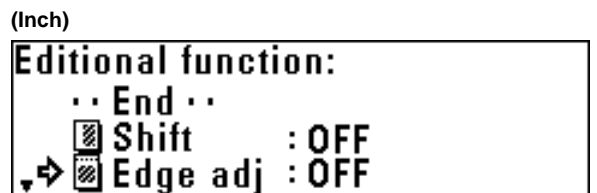

3 Press the OK key.

- To make a margin at the leading edge, proceed to the next step.
- To make a margin at the trailing edge, proceed to step 10.
- To execute whole sheet print, proceed to step 17.
- To cancel all margin copy settings, proceed to step 21.

> Setting a margin at the leading edge

4 Press the ▼ or ▲ key to select "Leading".

(Inch)

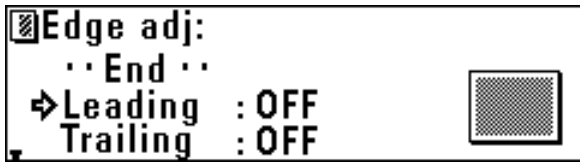

(Metric)



5 Press the OK key.

6 The margin setting will be displayed in the top line of the message display. "+" indicates the amount of margin to be added at the leading edge. "-" indicates the amount of margin to be cut at the leading edge.

- To change the preset value, press the ▼ or ▲ key to select "Change".
- To accept the value without change, ensure that "ON" is selected.

7 Press the OK key.

- If "Change" has been selected, proceed to the next step.
- If "ON" has been selected, proceed to step 10.

8 Press the ▼ or ▲ key to select "+" or "-" and use the numeric keys to enter the amount of margin.

(Inch)

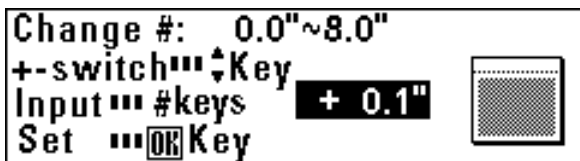

(Metric)



9 Press the OK key.

> Setting a margin at the trailing edge

10 To set a margin at the trailing edge, press the ▼ or ▲ key to select "Trailing".
To complete the setting, proceed to step 16.

(Inch)

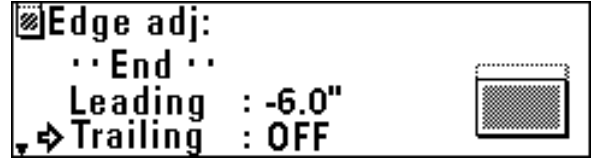

(Metric)



11 Press the OK key.

12 The margin setting will be displayed in the top line of the message display. "+" indicates the amount of margin to be added at the trailing edge. "-" indicates the amount of margin to be cut at the trailing edge.

- To change the preset value, press the ▼ or ▲ key to select "Change".
- To accept the value without change, ensure that "ON" is selected.

13 Press the OK key.

- If "Change" has been selected, proceed to the next step.
- If "ON" has been selected, proceed to step 16.

14 Press the ▼ or ▲ key to select "+" or "-" and use the numeric keys to enter the amount of margin.

(Inch)

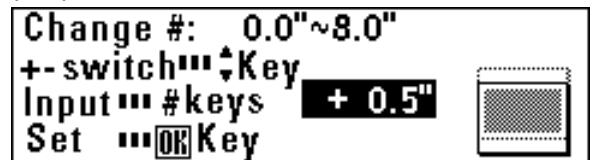

(Metric)



15 Press the OK key.

16 To complete the setting, ensure that "End" is selected and press the OK key.
The machine will return to the basic screen.

> Setting whole sheet print

17 Press the ▼ or ▲ key to select "Whole".

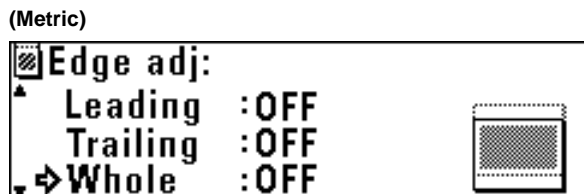
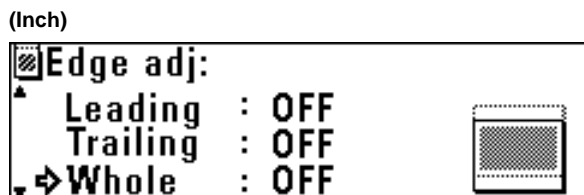

18 Press the OK key.

19 Press the ▼ or ▲ key to select "ON".

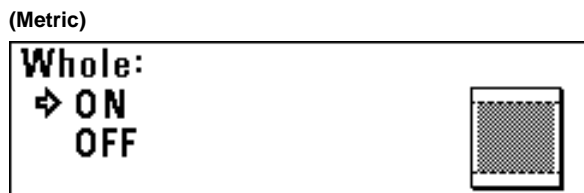
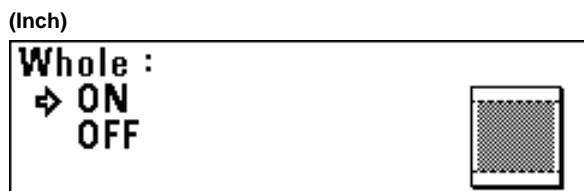

20 Press the OK key. To complete the setting, ensure that "End" is selected and press the OK key. The machine will return to the basic screen.

> Canceling all margin copy settings

21 To cancel all margin copy settings, press the ▼ or ▲ key to select "Cancel" and press the OK key. The machine will return to the basic screen.

(3) Border Erase mode

This mode eliminates the images around the edges of copies. The erase width can be set to up to 8" [200 mm] in 0.1" [1 mm] increments.

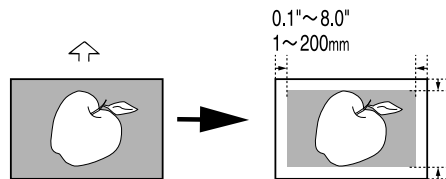

NOTE

• The default value of the erase width can be set by using "Ⓣ Default of edit. Function" of the default setting. (Page 7-7)

1 Press the Editing key.

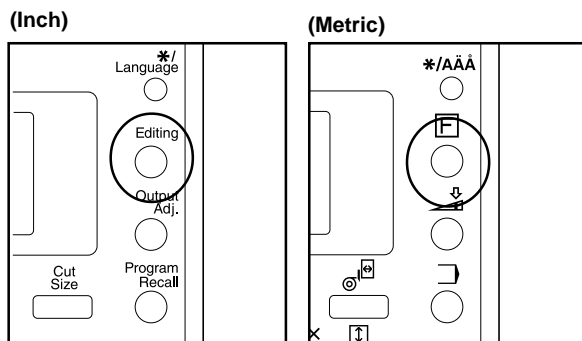

2 Press the ▼ or ▲ key to select "B. erase".

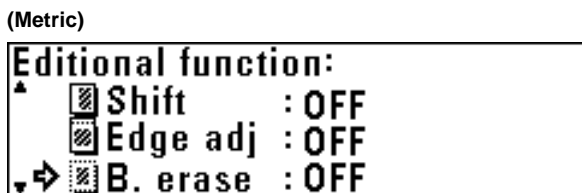
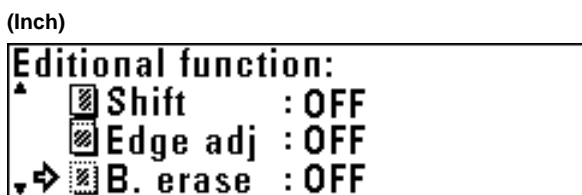

3 Press the OK key.

- 4** The erase width setting will be displayed in the top line of the message display.
- To change the preset value, press the ▼ or ▲ key to select "Change".
 - To accept the value without change, ensure that "ON" is selected.

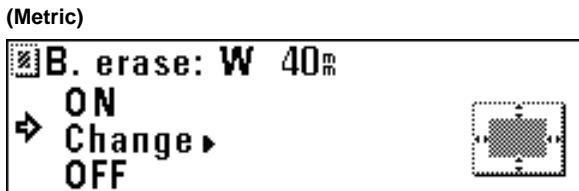
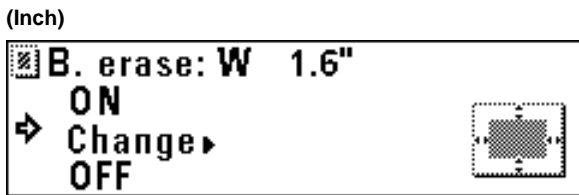

- 5** Press the OK key.
- If "Change" has been selected, proceed to the next step.
 - If "ON" has been selected, the machine will return to the basic screen.

- 6** Use the numeric keys to enter the erase width.

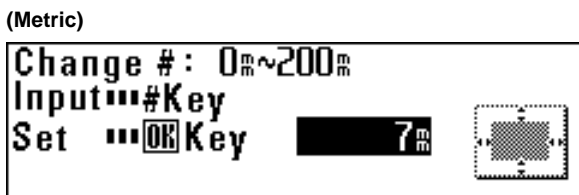
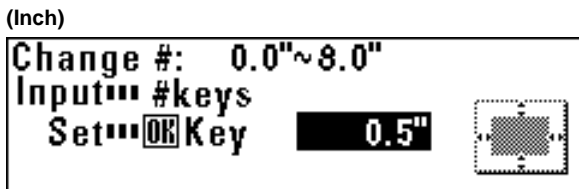

- 7** Press the OK key.
The machine will return to the basic screen.

(4) Mirror mode

This mode makes copies that are mirror images of the original in the side to side direction.

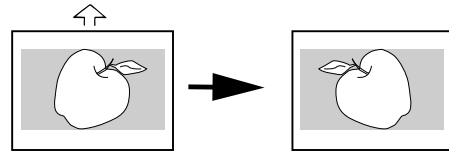

- 1** Press the Editing key.

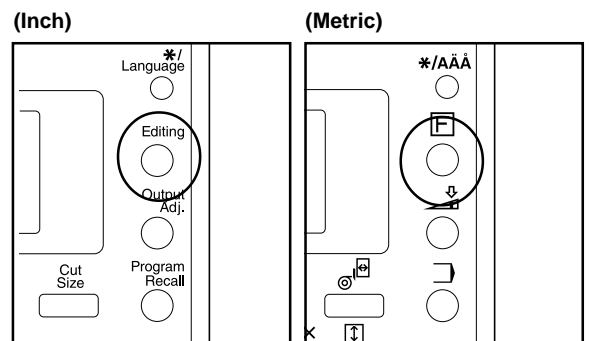

- 2** Press the ▼ or ▲ key to select "Mirror".

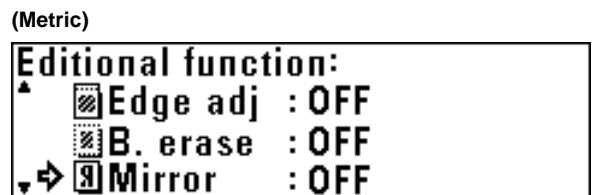
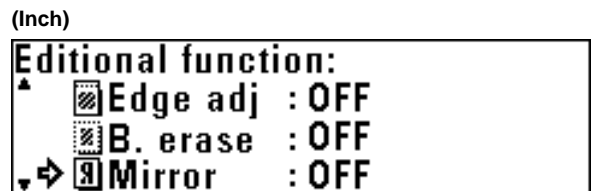

- 3** Press the OK key.

4 To make mirror copies, press the ▼ or ▲ key to select "ON".

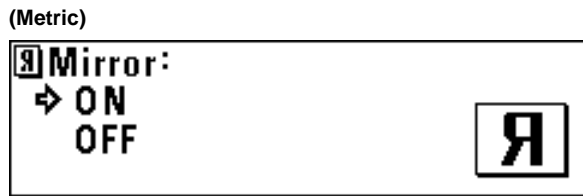
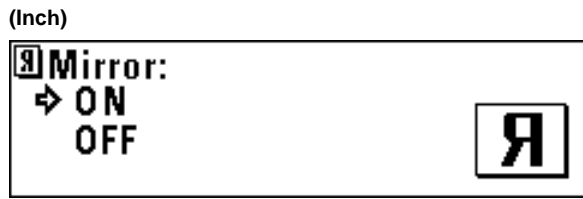

5 Press the OK key. The machine will return to the basic screen.

(5) Rotation mode

This mode rotates original images by 90 degrees.

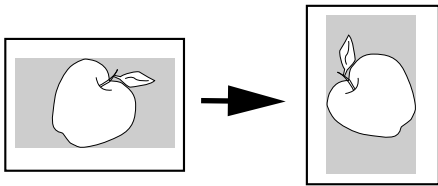

1 Press the Editing key.

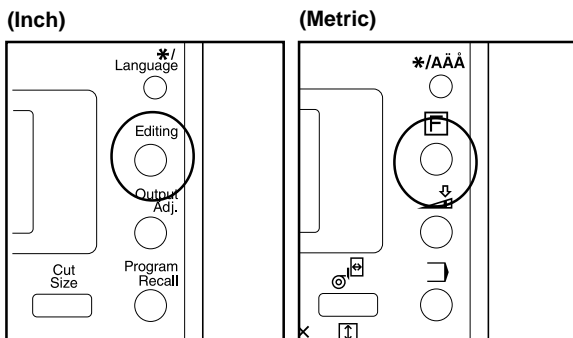

2 Press the ▼ or ▲ key to select "Rotate".

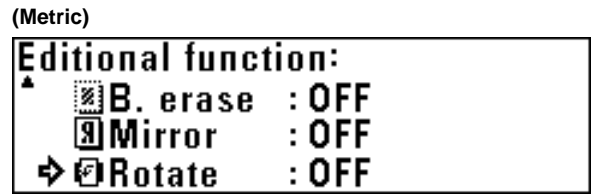
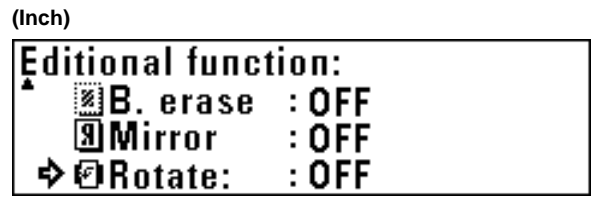

3 Press the OK key.

4 To rotate images, press the ▼ or ▲ key to select "ON".



5 Press the OK key. The machine will return to the basic screen.

3. Sort/Group copy

(1) Sort copy

This mode makes collated sets of copies from multiple originals.

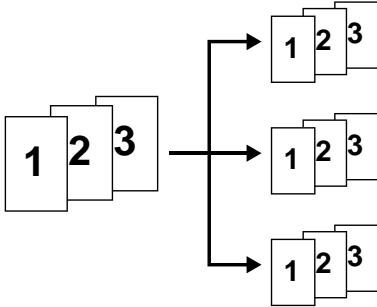

- 1 Press the Sort/Group key. The Sort/Group indicator will light up.

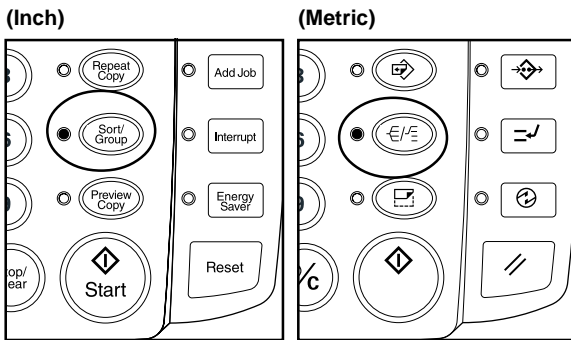

- 2 Make copy settings such as the number of copies.



- 3 Set the first original. Scanning of the original will start and one copy of the original will be output.

- 4 When the message "Insert next original" appears, make copy settings for the next original.



- 5 Set the next original. Scanning of the original will start. Only one copy of the scanned original will be output. Repeat steps 4 and 5 for remaining originals.

NOTE

- The maximum number of originals that can be scanned is 60. For the maximum number in job reserve, see "Maximum Jobs" of the default setting on page 7-6.

- 6 When scanning of originals is complete, press the OK key.

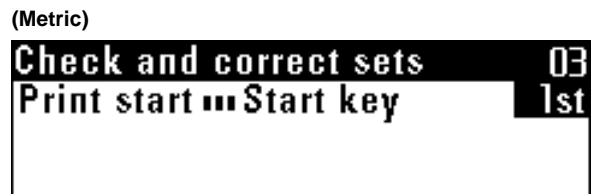

- 7 To change the number of copies, enter the number using the numeric keys.

8 Press the Start key. Copying of the remaining sets will start.

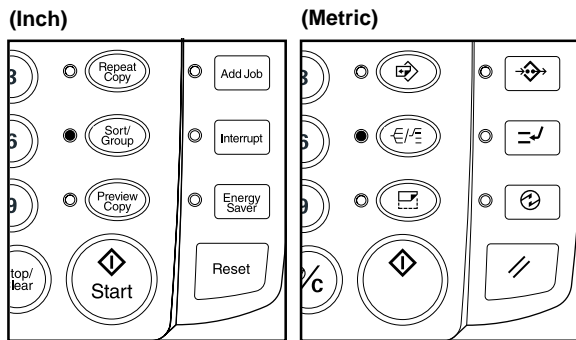

(2) Group copy

This mode makes multiple copies grouped by original.

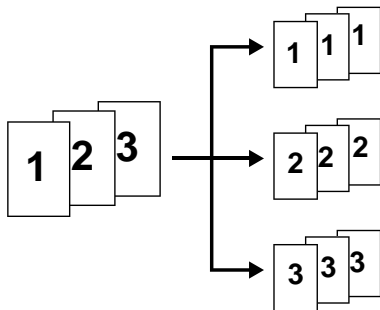

1 Press the Sort/Group key twice. The Sort/Group indicator will light up.

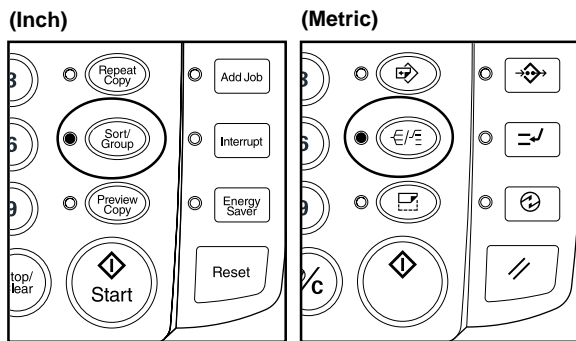

2 Make copy settings such as the number of copies.

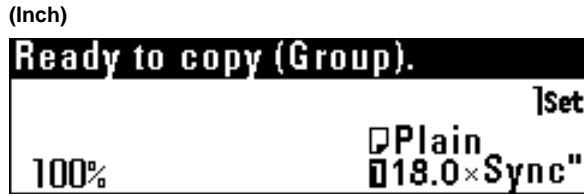

NOTE

- The number of copies cannot be changed when an original is being scanned or after an original is scanned.

3 Set the first original. Scanning of the original will start and copies will be output.

4 When the message "Insert next original" appears, make copy settings for the next original.



5 Set the next original. Scanning of the original will start. Repeat steps 4 and 5 for remaining originals.

NOTE

- The maximum number of originals that can be scanned is 60. For the maximum number in job reserve, see "@ Maximum Jobs" of the default setting on page 7-6.

6 When scanning of originals is complete, press the OK key.

CHAPTER 6 CONVENIENT FUNCTIONS

1. Adjustment Functions

NOTE

Use these settings to temporarily adjust copy finishing. These settings will be reset when the Reset key is pressed or the auto clear function is activated to reset the machine to the initial state.

(1) Inclination adjustment

Use this function when the original image is inclined.

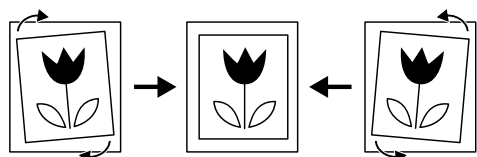

1 Press the Output Adj. key.

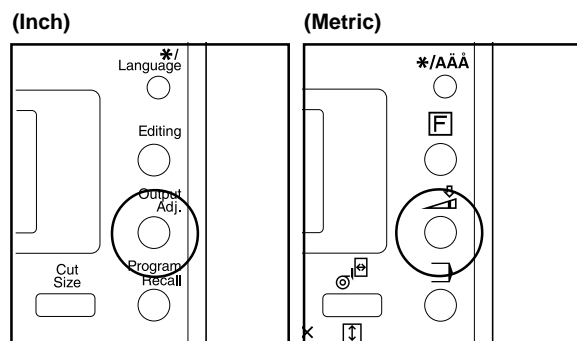

2 Press the ▼ or ▲ key to select “Adj.incline”.

(Inch)

```
Adjustment function:
.. End ..
➡ Adj.incline : OFF
▼ Fusing size : OFF
```

(Metric)

```
Adjustment function:
.. END ..
➡ Adj. incline : OFF
▼ Fusing size : OFF
```

3 Press the OK key.

4 Press the ◀ or ▶ key to set the angle for correction.
The angle can be set to the right or left between 0.0° to 1.0° in 0.1° increments or to 1.2° or 1.5°.

(Inch)

```
Adj.Inclin:left 1.5°~right 1.5°
Adj ◀▶Key
Set OKKey 0.1°
```

(Metric)

```
Adj. Inclination: left 1.5°~right 1.5°
Adj ◀▶Key
Set OKKey L 0.1°
```

5 Press the OK key.

6 Press the Output Adj. key. The machine will return to the basic screen.
The symbol that indicates inclination adjustment will appear at the bottom of the display.

(2) Copy size fine adjustment

Set this function when the copy image size is different from the original image size.

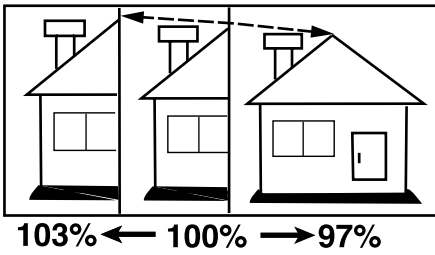

1 Press the Output Adj. key.

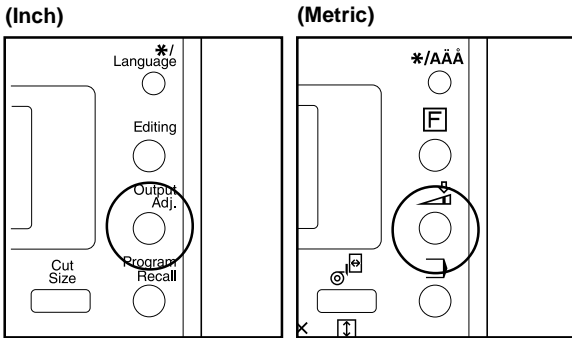

2 Press the ▼ or ▲ key to select "Fusing size".

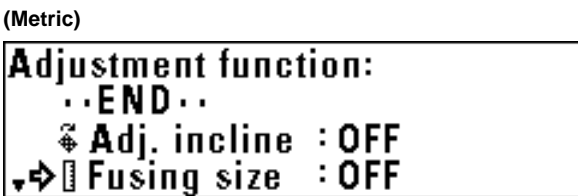
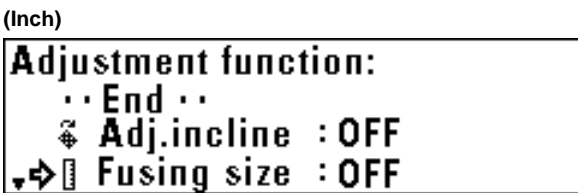

3 Press the OK key.

4 To adjust the copy size in the widthwise (X) direction, press the ◀ or ▶ key.

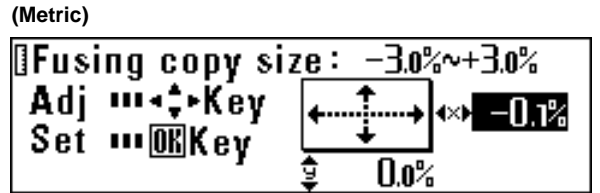
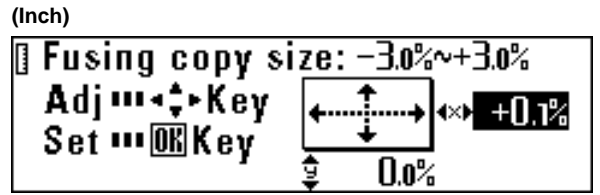

5 To adjust the copy size in the lengthwise (Y) direction, press the ▼ or ▲ key.

The size can be set between -3.0% and 3.0% in 0.1% increments.

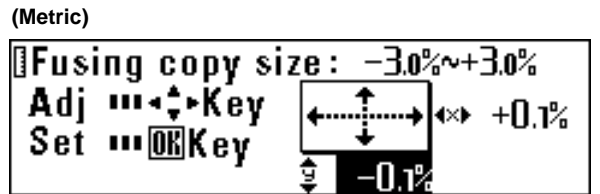
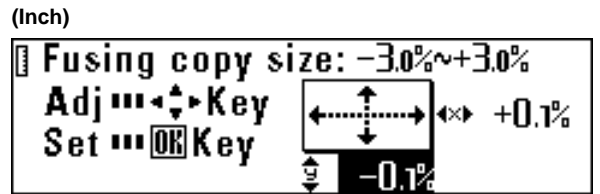

6 Press the OK key.

7 Press the Output Adj. key.
The machine will return to the basic screen. The symbol that indicates copy size fine adjustment will appear at the bottom of the display.

(3) Fixing Temperature Fine Adjustment

Set this function to adjust finely the fixing temperature. Adjusting the fixing temperature affects the fixing quality of toner. Adjust the fixing temperature upward for thick paper and downward for thin paper.

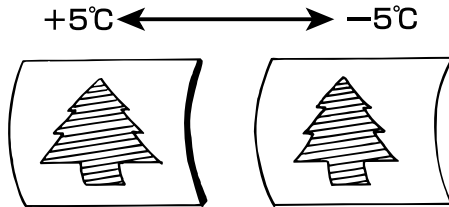

5 Press the OK key.

6 Press the Output Adj. key.
The machine will return to the basic screen. The symbol that indicates fixing temperature fine adjustment will appear at the bottom of the display.

1 Press the Output Adj. key.

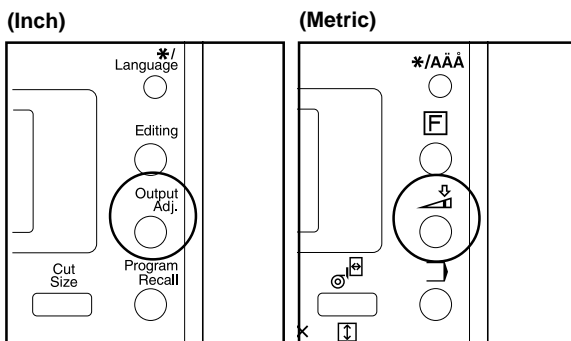

2 Press the ▼ or ▲ key to select "Fusing temp" ["Set fixing temp."].

3 Press the OK key.

4 Press the ▼ or ▲ key to adjust the fixing temperature.
The fixing temperature can be set between -5°C and 5°C in 1°C increments.



2. Repeat Copy Function

This machine stores image data in memory and then performs copying.

The repeat copy function allows the image data in memory to be used for repeated copying. The copy contrast and the magnification ratio can be changed for repeat copy.

Stored image data remains until the original image of the next job is stored or the auto clear function is activated. The image data in memory, however, can be deleted.

NOTE

- The repeat copy function can be disabled or limited by changing the setting of “17 Permit repeat” [“Permit repeat copy”] of the default setting. (Page 7-6)
- Although the copy settings can be changed for a repeat copy, “Mirror”, “Sort/group”, and “Default setting” cannot be changed.
- If the magnification ratio in repeat copying is decreased from the first copying, memory may be insufficient.
- If the magnification ratio in the first copying is 99.9% or less, the ratio in repeat copying cannot be increased from the ratio in the first copying by more than 10%.

(1) How to make a repeat copy

- 1 After a copy run is complete, the message “Repeat Copy ... Repeat Key” will appear. Press the Repeat Copy key. The Repeat Copy indicator will light up and the message “Repeat copy OK.” will appear.

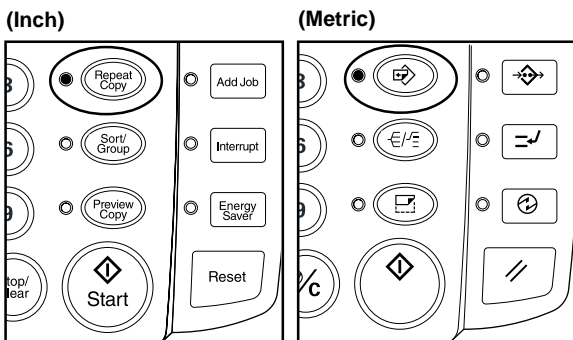

- 2 When a prompt for repeat copy code appears, enter the repeat copy code using the numeric keys. (The default setting is 4850.)

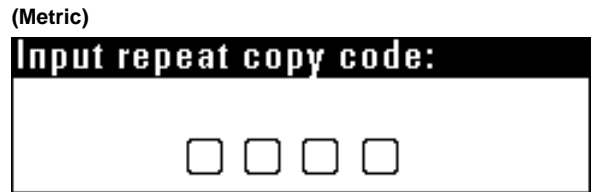
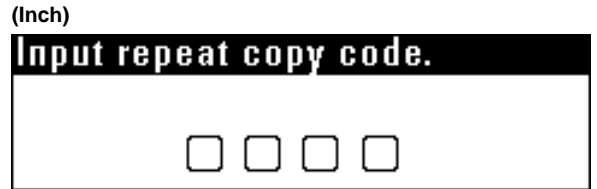

- 3 Change copy settings as needed.

- 4 Press the Start key. Copying will start.

(2) Repeat copy after sort/group

To change the number of copies after sort or group copying, select “Additional copy”. To copy onto the same size paper with the AMS function, select “AMS mode for all originals”.

NOTE

- If “AMS mode for all originals” is selected, the settings that can be changed are paper source, paper length, paper material, and number of copies.

- 1 After a copy run is complete, the message “Repeat Copy ... Repeat Key” will appear. Press the Repeat Copy key. The Repeat Copy indicator will light up and the message “Repeat copy OK.” will appear.

- 2 When a prompt for repeat copy code appears, enter the repeat copy code using the numeric keys. (The default setting is 4850.)

- 3** If only the number of copies is to be changed, press the ▼ or ▲ key to select "Additional copy".
To change copy settings, press the ▼ or ▲ key to select "AMS mode for all originals".

(Inch)

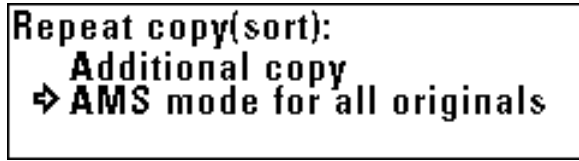

(Metric)

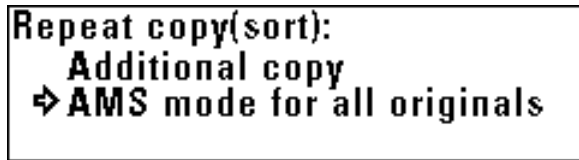

- 4** Press the OK key.
- If "Additional copy" has been selected, proceed to the next step.
 - If "AMS mode for all originals" has been selected, proceed to step 6.

- 5** Use the numeric keys to enter the number of copies. Proceed to step 7.

(Inch)



(Metric)

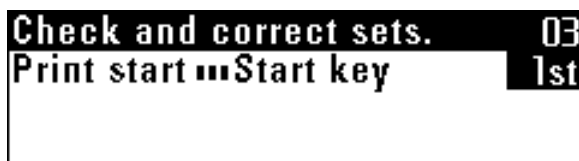

- 6** Change copy settings.

(Inch)



(Metric)

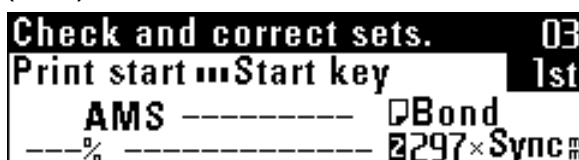

- 7** Press the Start key. Copying will start.

(3) Deleting Image Data

If the Reset key is pressed when repeat copy has been set, the image data in memory will be deleted.

To prevent image data from being deleted by mistake, a confirmation screen for image deletion can be displayed. Set "Delete memory" of the default setting to "Check data of repeat copy". (Page 7-6) If "Check data of repeat copy" is set, when the Reset key is pressed after repeat copy has been set, the confirmation screen shown below will appear.

(Inch)

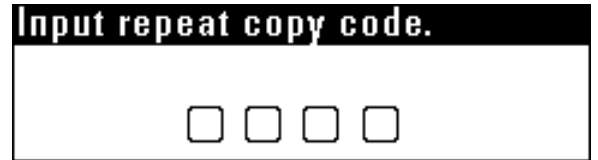

(Metric)

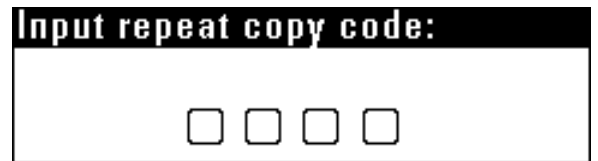

- ① Press the ▼ or ▲ key to select a choice.
If "Cancel repeat copy(delete)" is selected, the image data will be deleted and the machine will return to the initial state.
If "Continue repeat copy" is selected, copy settings will be cleared but image data will not be cleared.
- ② Press the OK key.

3. Preview Copy

When copying a long original, this function can be used to copy onto paper of the minimum length to check the copy functions and copy contrast, allowing waste of paper to be reduced. This machine provides the following preview copy functions.

● **Preview image**

If some editing functions or zoom mode are set or paper material is changed, output a preview image sample.

A sample copy from the current copy settings will be cut in length of 11" (279 mm) and output. Check the sample copy and adjust the copy settings.

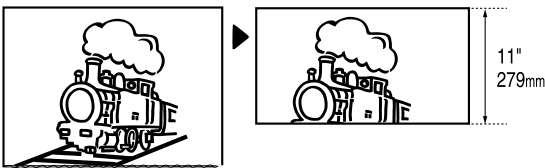

● **Preview contrast**

A sample copy with seven steps of copy contrast is output. The part of an original of 0 to 237" [0 to 6000 mm] from the leading edge is used as a sample and a copy in length of 13" [330 mm] (145" [370 mm] for photo original) is output. Check the sample copy and adjust the copy contrast setting.

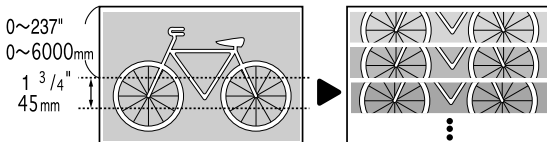

NOTE

• Preview image and preview contrast can be changed by using "Ⓜ Adj. preview copy" of the default setting. (Page 7-7)

1 Set the copy settings such as copy functions and copy contrast as needed.

2 Press the Preview Copy key. The Preview Copy indicator will light up.

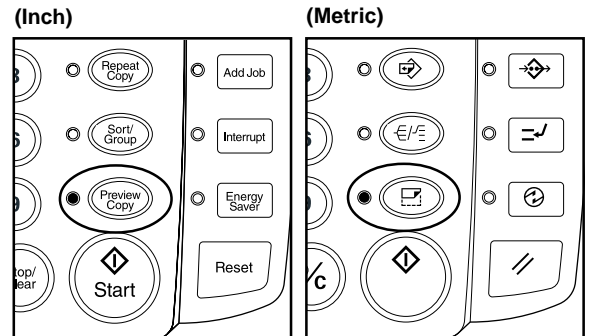

* When making a preview contrast sample, use the numeric keys to input the leading edge position of the original.

(Inch)

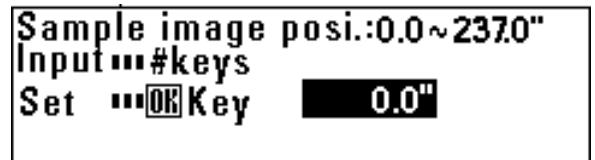

(Metric)

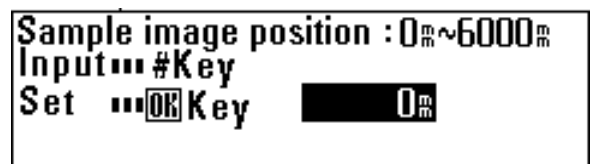

3 Set an original. Copying will start and a sample copy will be output.

4 Check the copy and adjust the copy settings.
If the mirror mode is changed, restart from step 1.

5 Press the Repeat Copy key. To output a sample copy again, press the Start key.
To start copying of the whole original, proceed to the next step.
If "Ⓜ Permit repeat" ["Ⓜ Permit repeat copy"] of the default setting is set to "Unpermit", reset the original and make a copy. If "Code number" ["Id-code"] is set, use the numeric keys to enter the repeat copy code. (Page 7-6)

6 Press the Preview Copy key. The Preview Copy indicator will go out.

7 Check the number of copies and press the Start key. Copying will start.

4. Job Reserve Function

A copy job can be reserved while a copy job is being run. The reserved copy job will start automatically after the current job is complete.

NOTE

- A copy job cannot be reserved when an original is being scanned, when any original remains under the original cover, when interrupt copy or preview copy is being output or repeat copying with reduction is being performed.
- The number of jobs that can be reserved is limited by “Ⓜ Maximum Jobs” of the default setting. (Page 7-6) The maximum number of jobs, however, may not be reserved because of memory overflow.

(1) Reserving a job

- 1 Press the Add Job key.
The message “Job reserve copy OK.” will appear and the Add Job indicator will light up.

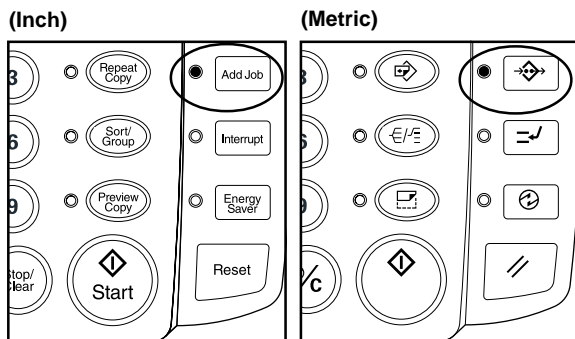

NOTE

- A job may not be reserved when the first copy is being output. In this case, wait until copying is complete and then press the Add Job key again.

- 2 Set copy settings as needed and set the original for job reserve.
Scanning of the original will start.
When job reserve is complete, a job number will be displayed.

(Inch)



(Metric)

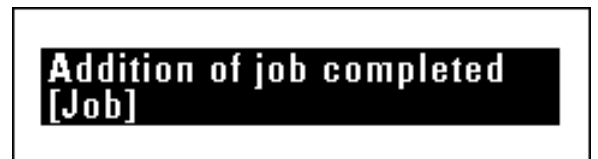

- 3 To reserve another job, repeat step 2.

- 4 Press the Add Job key. The Add Job indicator will go out and the machine will return to the basic screen.
When output of the current job is complete, output of the reserved job will start automatically.

(Inch)

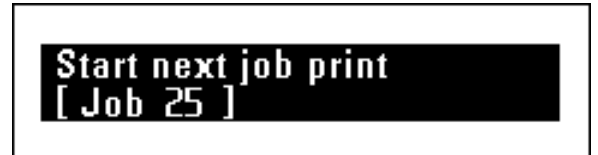

(Metric)



(2) Canceling job reserve

To cancel job reserve, perform the following procedure.

- 1 Press and hold down the Add Job key. (more than two seconds)

The job cancel screen cannot be selected from the job reserve mode. Press the Add Job key to turn off the Add Job indicator before executing this step.

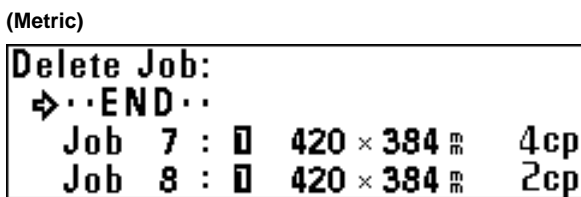
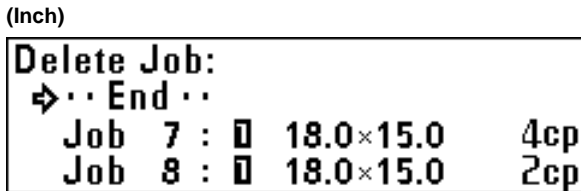
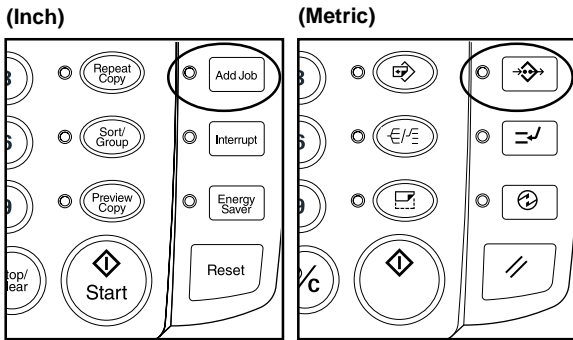

- 2 Press the ▼ or ▲ key to select a job number to be deleted.

- 3 Press the OK key. A confirmation screen for canceling job reserve will appear.

- 4 Press the ▼ or ▲ key to select "Yes".

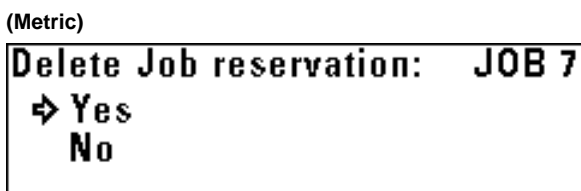
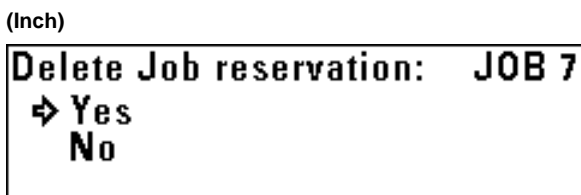

- 5 Press the OK key. The job reserve will be canceled.

- 6 To cancel other jobs, repeat steps 2 to 6. To complete the operation, ensure that "End" is selected and press the OK key.



- 7 Press the Add Job key. The Add Job indicator will go out and the machine will return to a copy screen if a copy job is being run.

5. Program Function

Frequently used settings can be registered for setting copy conditions effectively. Up to 10 programs can be registered.

(1) Registering a program

1 Set the copy conditions to be registered using the operation panel.



2 Press the */Language key.

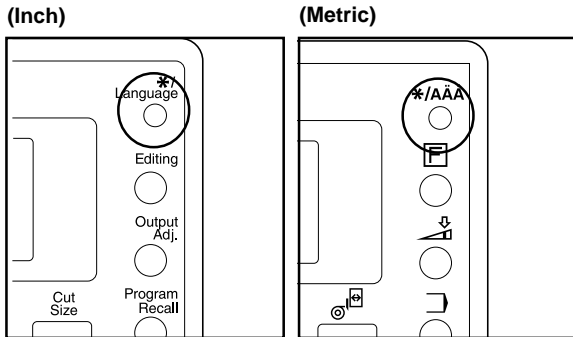

3 Press the ▼ or ▲ key to select "Program register mode." ["Program mode."].

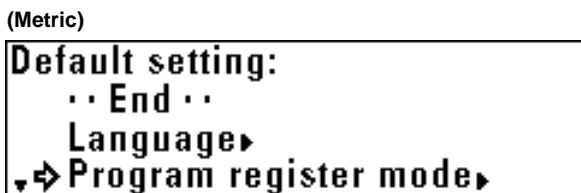
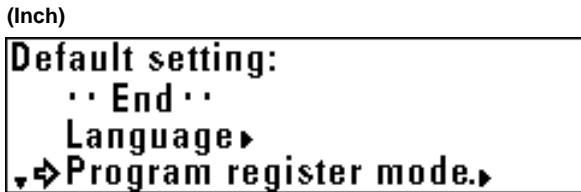

4 Press the OK key.

5 Press the ▼ or ▲ key to select a program number to which the copy conditions selected in step 1 are to be registered from "Job Program #1" to "Job Program #10"



6 Press the OK key. Copy conditions that have been registered will be displayed. The copy conditions can be checked by pressing the ◀ and ▶ keys to switch the screen.

7 Press the OK key.

8 A confirmation for overwriting will appear. Press the ▼ or ▲ key to select "Yes".

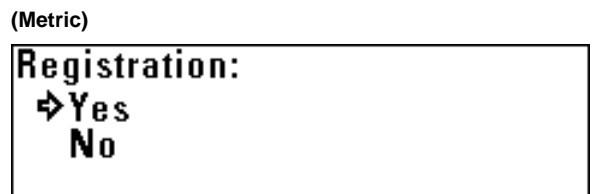
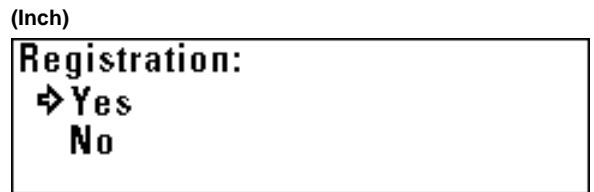

9 Press the OK key. The machine will return to the basic screen.

(2) Program Recall

1 Press the Program Recall key.

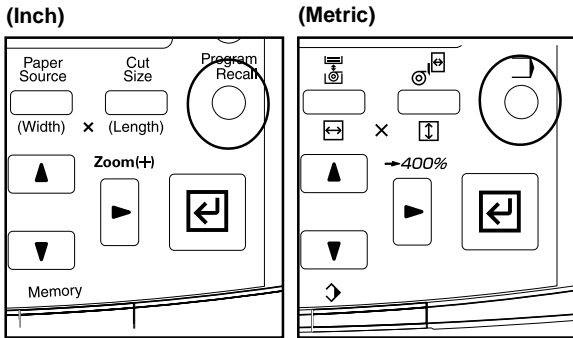

2 Press the ▼ or ▲ key to select a program number to be recalled from “Job Program #1” to “Job Program #10”

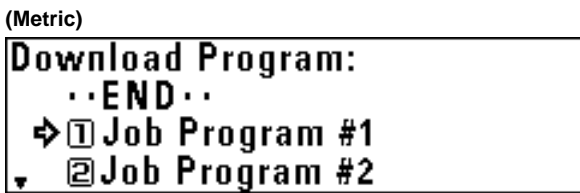
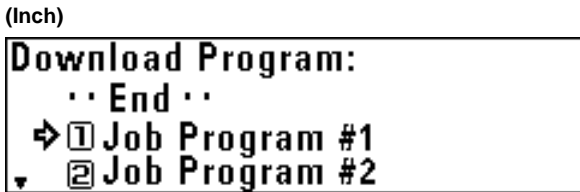

5 Press the OK key.
A confirmation screen for program recall will appear.

6 Press the ▼ or ▲ key to select “Yes”.

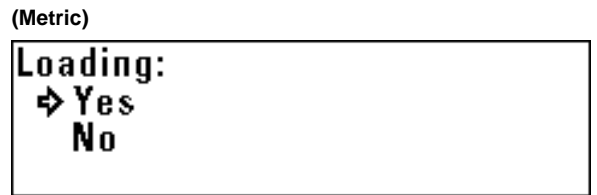

7 Press the OK key.
The program will be recalled and the machine will return to the basic screen.
Copy conditions can be changed.

NOTE

- If check of registered copy conditions is not needed, enter the program number using a numeric key. (For “Job Program #10”, press the 0 key.) The program will be recalled and the machine will return to the basic screen.

3 Press the OK key.
Registered copy conditions will be displayed. To check the details of registered copy conditions, proceed to the next step. Otherwise, proceed to step 5.

4 Press the ◀ or ▶ key to switch the screen to check the details of registered conditions.

6. Interrupt Copy

If the Interrupt key is pressed while a copy job is being run, the current copy will be interrupted and another copy job can be run.

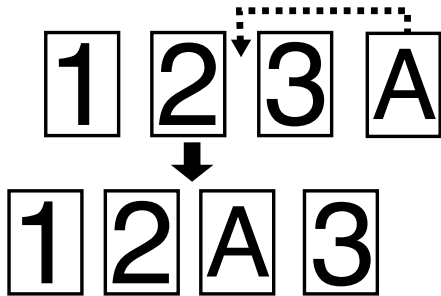

NOTE

- If the Interrupt key is pressed after an interrupt copy is complete, the interrupted job can be resumed under the original copy conditions.
- Interrupt copy can function except when an original is being scanned.
- When originals are being scanned continuously in the sort mode, interrupt copy cannot function.

- 1 Press the Interrupt key while a copy is being output. The Interrupt indicator will light up. Copying will be interrupted after a copy that is being output is ejected.

- 2 Set copy conditions as needed and set an original for interrupt on the original table. Interrupt copy will start.

- 3 After copying is complete, to make another interrupt copy, press the Reset key and repeat step 2.

- 4 When the interrupt copy is complete, press the Interrupt key. The interrupt indicator will go out and the machine will restore the copy settings for interrupted copy.

- 5 To resume interrupted copy, press the Start key.

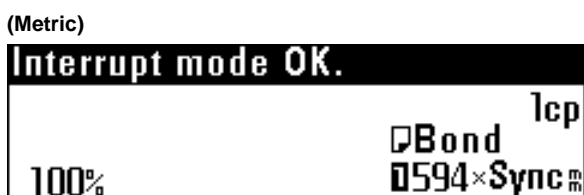
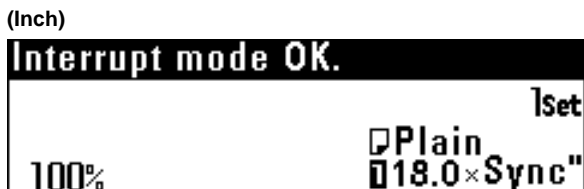
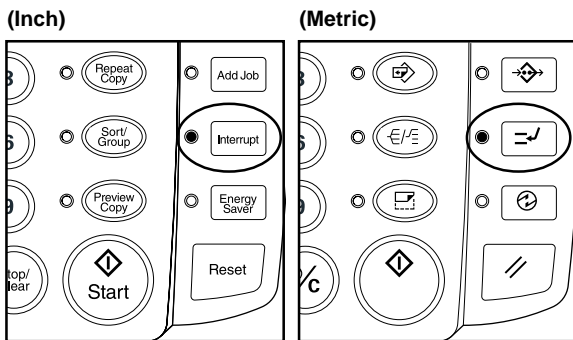

7. Auto Clear Function

The machine automatically returns to the initial state when a certain time elapses after a copy run is complete. (The copy contrast setting, however, does not return to the initial setting.) Before the auto clear function is activated, copying with the same copy setting and the same number of copies can be repeated. Also the repeat copy function can be used for copying.

The time that elapses before the auto clear function is activated (auto clear time) can be set to 30 seconds, 1 minute, 3 minutes, and 5 minutes by using “⑨ Timer Set” of the default setting. (Page 7-2)
To disable the auto clear function, set “⑦ Auto Clear Timer” [“Auto clear”] to “OFF”. (Page 7-2)

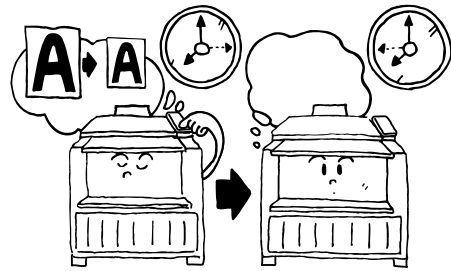

8. Energy Saver Function

When this machine is not used for some time, press the Energy Saver key. Only the Energy Saver indicator will light up and the machine enters a resting state.

If the Energy Saver function is used, warm up time is shorter than the warm up time after the main power switch is turned off (O) and then on again. If copy operation is not used for a certain time, the machine will automatically enter a resting state when the auto energy saver time elapses. The factory default setting of the auto energy saver time is 15 minutes. The auto energy saver time can be set to from 5 minutes to 45 minutes in 5 minute increments by using “⑨ Timer Set”. (Page 7-2)

To restart copying, press the Energy Saver key again.

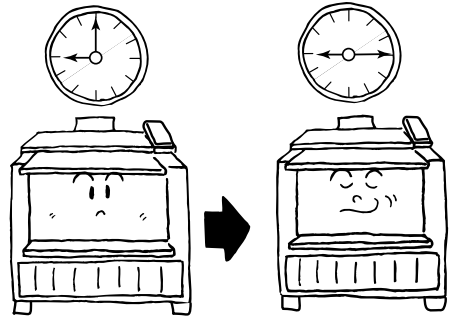

9. Auto Shut-off Function

The auto shut-off function automatically turns off (O) the power if no copying operation is performed for a certain time.

Copiers generally consume much power during standby because standby time is much longer than copying time. The function of automatic turning off (O) the copier can reduce unnecessary power consumption in standby or at night where power is left on by mistake, resulting in reduction of electricity bill.

To restore from the auto shut-off, turn the main power switch on (I).

The factory default setting of the time that elapses before the auto shut-off is activated (auto shut-off time) is 90 minutes.

The auto shut-off time can be set to from 15 to 120 minutes in 5 minute increments by using “⑨ Timer Set” of the default setting. (Page 7-2)

To disable the auto shut-off function, see “⑧ Auto Shut-off Time” of the default setting. (Page 7-2)

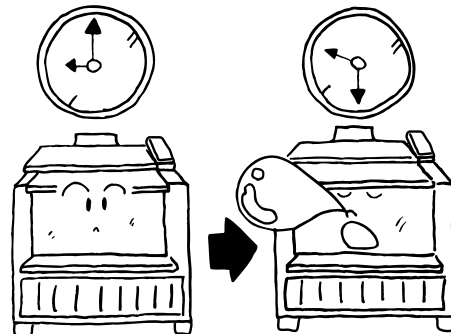

CHAPTER 7 MANAGEMENT AND SETTING

The values selected when the main power switch of this machine is turned on (1) or when the Reset key is pressed (default) can be changed. Change each setting as needed.

The default setting items are classified into "Machine default" concerning the operation of this machine and "Copy default" concerning copy conditions selected with priority depending on the details. Also these are classified based on the authorization into "User" for which settings are restricted and "Manager" for which all settings can be accessed. To change the default setting with "Manager" authorization, a password must be entered. For each setting, see "List of Default Setting".

1. List of Default Setting

(1) Machine default

● Items common to user/manager

Setting item	Details	Selectable values	Default	Page
① Paper width adjustment	If this item is set to "Input width(# key)", a non-standard paper width can be set. Use the numeric keys to enter the paper width for each paper source. If a non-standard paper width is entered, the APS function cannot be used.	For each paper source Auto/Input width 8.5" to 36.2"(210 mm to 920 mm)	Auto	7-10
② Paper working	If this item is set to "ON", a paper material can be registered for each paper source. Fixing temperature, copy size, and fix/unfix of roll end will be set based on the registered paper material.	ON/OFF	OFF	7-11
③ Paper material adjustment	If "Paper working" is set to "ON", a paper material can be set for each paper source including the bypass table. If "Custom" is selected, fixing temperature, copy size, etc. will be set based on "⑫ Custom paper adj." ["Custom paper material adj."].	For each paper source Plain/ vellum/ film/ custom	Plain	7-11
④ Roll end adjustment	Whether paper roll end is fixed to the core of the roll or not is set. If "Fix" is selected, paper will be automatically cut when paper runs out.	For each paper material Fix/Unfix	Unfix (Fix for film)	7-11
⑤ Display contrast	Liquid crystal display on the operation panel is adjusted.	1 to 7	4	7-12
⑥ Orig.eject direct	If this item is set to "Discharge to front" ["Output to front"], finished originals will return to the front side. If this item is set to "Discharge to back" ["Output to back"], originals will be ejected to the rear side of the machine.	Front/rear	Rear	7-12

CHAPTER 7 MANAGEMENT AND SETTING

● Items for manager only

Setting item	Details	Selectable values	Default	Page
⑦ Auto Clear Timer [Auto clear]	If this item is set to "ON", copy settings will return to the default settings when no operation is performed for a certain time. (The copy contrast, however, will not return to the default setting.)	ON/OFF	ON	7-12
⑧ Auto Shut-off Time [Auto Shut off Time]	If this item is set to "Shut off mode", the main power switch will be automatically turned off when no copy operation is performed for a certain time. When a printer/scanner controller (optional) is installed, this item can be set to "Sleep mode" for saving most power consumption.	Shut off mode/ Sleep mode/ OFF	Shut off mode	7-13
⑨ Timer Set	The time that elapses before auto clear, auto energy saver or auto shut off is activated is set respectively. If the copier is used frequently, it is recommended that the time for auto shut off be longer. If the copier is not used long time, it is recommended that the time be shorter.	Auto clear time 30 seconds, 1 minute, 3 minutes, 5 minutes Auto energy saver time 5 to 45 minutes in 5 minute increments Auto shut-off time 15 to 120 minutes in 5 minute increments	1 minute 15 minutes 90 minutes	7-13
⑩ Copy size adjustment	Copy size can be adjusted for each paper material. * If this setting is changed when data remains in the image memory, the data will be cleared.	For each paper material X (widthwise direction) -3.0% to +3.0% Y (lengthwise direction) -3.0% to +3.0%	X: $\pm 0.0\%$ Y: $\pm 0.0\%$	7-14
⑪ Fusing temperature [Set fixing temp.]	The fixing temperature can be changed for each paper material. Set a higher temperature for thick paper and a lower temperature for thin paper. For custom paper, a fixing temperature for the paper material selected in "⑫ Custom paper adj." ["Custom paper material adj."] can be selected.	Plain 145°C, 155°C, 165°C Vellum 165°C, 175°C, 185°C Film 150°C, 160°C, 170°C Custom above paper material and each fixing temperature	155°C 185°C 150°C Vellum 165°C	7-14

Setting item	Details	Selectable values	Default	Page
⑫ Custom paper adj. [Custom paper material adj.]	Material, fixing temperature, and copy size for custom paper can be set. These settings are associated with custom settings of copy size and fixing temperature adjustment.	Plain 145°C, 155°C, 165°C Vellum 165°C, 175°C, 185°C Film 150°C, 160°C, 170°C Copy size: X (widthwise direction) -3.0% to +3.0% Y (lengthwise direction) -3.0% to +3.0%	Vellum 165°C X: ±0.0% Y: ±0.0%	7-15
⑬ Standard size set	Select the type of originals and paper to be used: "architecture" or "engineering" ["A sizes" or "B sizes"]. This setting affects the standard cut length and paper width and original width to be detected automatically by this machine.	Architecture/ engineering (A sizes/ B sizes)	Architecture (A sizes)	7-15
⑭ Auto roll over	If paper of the same size is set in multiple paper sources, when paper in a paper source runs out during copying, another paper source will be automatically selected and copying will continue. If "② Paper working" is set to "ON", however, auto roll over will not function between different paper materials of the same size.	ON/OFF	OFF	7-15
⑮ Management # [Management code change]	The password for the default setting for manager can be changed. * It is recommended to write the code down when it is changed.	0000 to 9999	4850	7-16

(2) Copy default
● Items common to user/manager

Setting item	Details	Selectable values	Default	Page
① Auto rotation mode	Whether rotation of original image is enabled or not can be selected for copying when paper of the same width as the original is not installed.	ON/OFF	OFF	7-16
② Zoom step [Zoom steps]	Increment of magnification ratio can be set to 1% or 0.1%. If the increment is set to 1%, the fractional portion of the number will be dropped for display and copying.	1%/0.1%	1%	7-16
③ Zoom register	Magnification ratios can be set to user No. 1 to 5 as choices for user setting zoom.	Zoom 25.0% to 400.0% XY zoom X (widthwise direction): 25.0% to 400.0% Y (lengthwise direction): 25.0% to 400.0%	Zoom 100.0%	7-16
④ Cut size register	Any length can be registered to user 1 and user 2 as choice of standard cut.	User 1/ user 2 11" to 237" [279 mm to 6000 mm]	User 1: 40" [1000 mm], user 2: 80" [2000 mm]	7-17
⑤ Exposure step [Exposure steps]	The number of exposure steps for adjusting with the copy contrast keys (◀ and ▶) can be set to "7 steps" or "13 steps".	7 steps/ 13 steps	7 steps	7-18
⑥ Auto/Manual exp.	The default exposure mode is set.	Auto, Normal, Normal darker, Normal lighter, Text/Line, Photo	Normal	7-18
⑦ Default exposure	The default position of exposure indicators can be selected. If Auto is selected, no indicator will light up.	1 to 7	4	7-18
⑧ Exposure adj.	Overall copy contrast in each exposure mode ("Auto exposure", "Normal originals", "Character/Line", and "Photo" can be adjusted.	For each exposure mode: 1 to 7	4	7-18

● Items for manager only

Setting item	Details	Selectable values	Default	Page
⑨ Standard drawer	Default paper source can be selected.	Paper source 1 (only if an optional roll unit is installed)/ paper source 2/ paper source 3/ bypass	Paper source 2	7-19
⑩ Auto select set	Default copy mode ("APS", "AMS", or "Manual") can be selected.	APS/ AMS/ Manual	Manual	7-19
⑪ AMS mode	If a paper source is specified when the APS mode has been set, copying with a preset magnification ratio or the AMS mode will be selected. Whether copying with a preset magnification ratio ("OFF") or the AMS mode ("ON") is selected can be specified.	ON/OFF	OFF	7-19
⑫ Method copy start	If "Start key" is selected, scanning of original will start when the Start key is pressed after an original has been set. If "Auto start" is selected, scanning of original will start automatically when an original is set.	Auto start/ Start key	Auto start	7-20
⑬ Start late time	If "⑫ Method copy start" is set to "Auto start", the time between setting of original and start of copying can be set.	0.5 sec./ 1 sec./ 2 sec./ 3 sec./ 4 sec./ 5 sec.	0.5 sec.	7-20
⑭ Paper cut [Select cut. Method]	Default paper cut size can be selected. "User 1" and "User 2" are the lengths that have been set by "③ Cut size register".	For A sizes (metric machine) Synchronized cut/ 1189 mm/ 841 mm/ 594 mm/ 420 mm/ 297 mm/ User 1, 2 For B sizes (metric machine) Synchronized cut/ 1030 mm/ 728 mm/ 515 mm/ 364 mm/ User 1, 2 Architecture (inch machine) Synchronized cut/ 12.0"/ 18.0"/ 24.0"/ 36.0"/ 48.0"/ User 1, 2 Engineering (inch machine) Synchronized cut/ 11.0"/ 17.0"/ 22.0"/ 34.0"/ 44.0"/ User 1, 2	Synchronized cut	7-20

CHAPTER 7 MANAGEMENT AND SETTING

Setting item	Details	Selectable values	Default	Page
⑮ Sync. Cut length	Whether paper cut length is displayed or not when synchronized cut is selected can be selected.	ON/OFF	OFF	7-20
⑯ Delete memory	If this item is set to "Check data of repeat copy", when the Reset Copy key is pressed in the repeat copy mode, a confirmation screen for deletion of image data will appear.	Delete/ Check data of repeat copy	Delete	7-21
⑰ Permit repeat	If this item is set to "Unpermit", the repeat copy function cannot be used. If this item is set to "Code number", the repeat copy code must be entered for repeat copy.	Permit/ Code number/ Unpermit	Permit	7-21
⑱ Repeat copy code change	The repeat copy code that must be entered if "⑰ Permit repeat" is set to "Code number" can be changed.	0000 to 9999	4850	7-21
⑲ Memory compress	The compression ratio of image data stored in memory can be set. If compression ratio is set to a higher level, the allowable number of originals that can be scanned will be larger but halftone (gray) image may be deteriorated. If "Non-compression" (high image quality) is selected, addition of memory may be needed. * If this setting is changed when data remains in the image memory, the data will be cleared.	Non-compression/ Standard-compression/ High-compression	Standard-compression	7-21
⑳ Maximum Jobs	The maximum number of jobs that can be reserved is set. Based on the number of jobs, the number of originals that can be scanned in the sort or group mode for job reserve is limited. The maximum number is 20 sheets for "5 jobs", 10 sheets for "10 jobs", and 5 sheets for "20 jobs".	5 jobs/ 10 jobs/ 20 jobs	5 jobs	7-22

Setting item	Details	Selectable values	Default	Page
<p>②① Default of edit. Function</p>	<p>Default values displayed in setting of the editing functions (Shift to up/down, Shift to left/right, Leading edge margin, Trailing edge margin, and Border Erase) can be changed.</p>	<ul style="list-style-type: none"> • Shift to up/down 8.0" up to 8.0" down [200 mm up to 200 mm down] • Shift to left/right 8.0" to left to 8.0" to right [200 mm to left to 200 mm to right] • Leading edge margin -8.0" to +8.0" [-200 to +200 mm] • Trailing edge margin -8.0" to +8.0" [-200 to +200 mm] • Border Erase 0.0" to 8.0" [0 to 200 mm] 	<p>0.4" down [10 mm down]</p> <p>0.4" to right [10 mm to right]</p> <p>+2.0" [+50 mm]</p> <p>+2.0" [+50 mm]</p> <p>0.4" [10 mm]</p>	<p>7-22</p>
<p>②② Adj. preview copy</p>	<p>Sample copy type for the preview copy function can be selected.</p>	<p>Preview image/ Preview contrast</p>	<p>Preview contrast</p>	<p>7-23</p>

2. Setting Method of Default Setting

(1) Setting method for user

1 Press the */Language key.

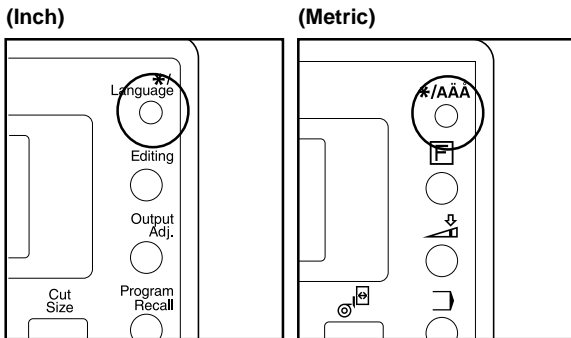

> To set the copy default, press the ▼ or ▲ key to select “Copy default”.

(Inch)



(Metric)



2 Press the ▼ or ▲ key to select “Default setting/User”.

(Inch)

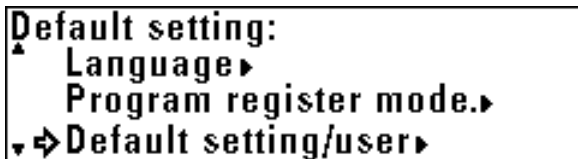

(Metric)



3 Press the OK key.

4 Select machine default or copy default.
> To set the machine default, press the ▼ or ▲ key to select “Machine default”.

(Inch)

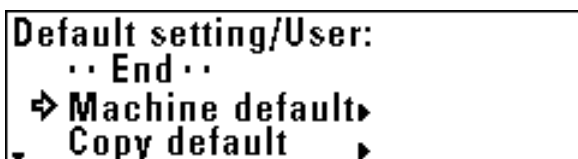

(Metric)

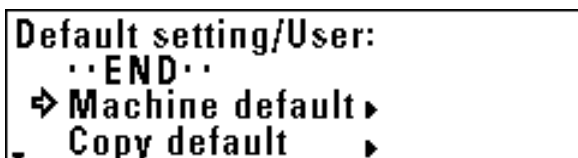

5 Press the OK key.

6 Press the ▼ or ▲ key to select a setting item and press the OK key. Set each item referring to the page indicated.

> **Items that can be selected from machine default**

- ① Paper width adjustment ... Page 7-10
- ② Paper working ... Page 7-11
- ③ Paper material adjustment ... Page 7-11
- ④ Roll end adjustment ... Page 7-11
- ⑤ Display contrast ... Page 7-12
- ⑥ Orig.eject direct ... Page 7-12

> **Items that can be selected from copy default**

- ① Auto rotation mode ... Page 7-16
- ② Zoom step ... Page 7-16
- ③ Zoom register ... Page 7-16
- ④ Cut size register ... Page 7-17
- ⑤ Exposure step [Exposure steps] ... Page 7-18
- ⑥ Auto/Manual exp. ... Page 7-18
- ⑦ Default exposure ... Page 7-18
- ⑧ Exposure adj. ... Page 7-18

7 To set another item, return to step 6. To complete the setting, press the ▼ or ▲ key to select “Default/back User” [“Default setting/back User”] and press the OK key. Press the ▼ or ▲ key to select “End”.

(2) Setting method for manager

1 Press the */Language key.

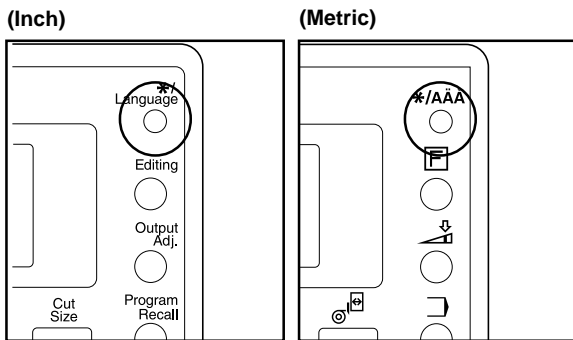

2 Press the ▼ or ▲ key to select "Default set/manager" ["Default setting/administrator"].

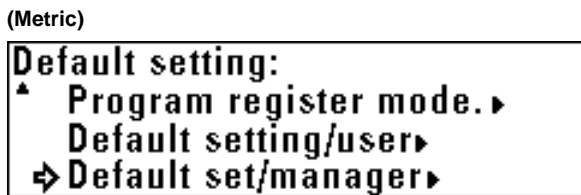
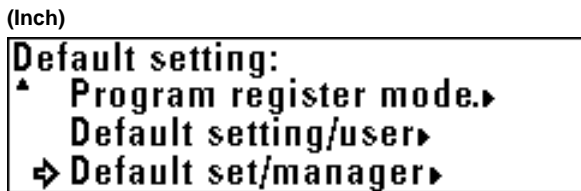

3 Press the OK key.

4 Use the numeric keys to enter a four digit password.
 * The factory default setting is "4850". This setting can be changed. ("Ⓜ Management #change" [Management code change] on page 7-3)

5 Select machine default or copy default.
 > To set the machine default, press the ▼ or ▲ key to select "Machine default".

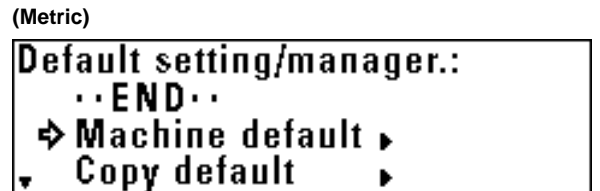
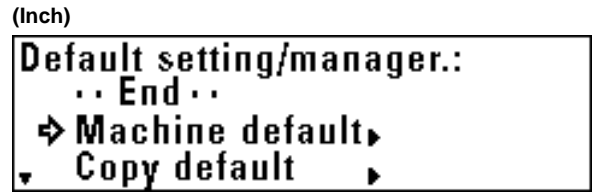

> To set the copy default, press the ▼ or ▲ key to select "Copy default".

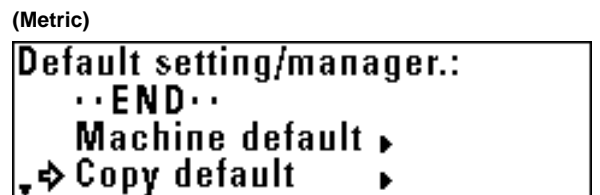
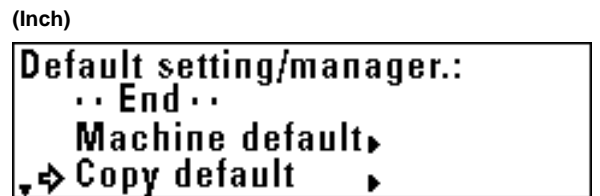

6 Press the OK key.

7 Press the ▼ or ▲ key to select a setting item and press the OK key. Set each item referring to the page indicated.

> **Items that can be selected from machine default**

- ① Paper width adjustment ... Page 7-10
- ② Paper working ... Page 7-11
- ③ Paper material adjustment ... Page 7-11
- ④ Roll end adjustment ... Page 7-11
- ⑤ Display contrast ... Page 7-12
- ⑥ Orig.eject direct ... Page 7-12
- ⑦ Auto Clear Timer [Auto clear] ... Page 7-12
- ⑧ Auto Shut-off Time ... Page 7-13
- ⑨ Timer Set ... Page 7-13
- ⑩ Copy size adjustment ... Page 7-14
- ⑪ Fusing temperature [Set fixing temp.] ... Page 7-14
- ⑫ Custom paper adj. ... Page 7-15
- ⑬ Standard size set ... Page 7-15
- ⑭ Auto roll over ... Page 7-15
- ⑮ Management # [Management code change] ... Page 7-16

> **Items that can be selected from copy default**

- ① Auto rotation mode ... Page 7-16
- ② Zoom step ... Page 7-16
- ③ Zoom register ... Page 7-16
- ④ Cut size register ... Page 7-17
- ⑤ Exposure step [Exposure steps] ... Page 7-18
- ⑥ Auto/Manual exp. ... Page 7-18
- ⑦ Default exposure ... Page 7-18
- ⑧ Exposure adj. ... Page 7-18
- ⑨ Standard drawer ... Page 7-18
- ⑩ Auto select set ... Page 7-19
- ⑪ AMS mode ... Page 7-19
- ⑫ Method copy start ... Page 7-19
- ⑬ Start late time ... Page 7-20
- ⑭ Paper cut [Select cut. Method] ... Page 7-20
- ⑮ Sync. Cut length ... Page 7-20
- ⑯ Delete memory ... Page 7-20
- ⑰ Permit repeat ... Page 7-21
- ⑱ Change repeat # [Repeat code change] ... Page 7-21
- ⑲ Memory compress ... Page 7-21
- ⑳ Maximum Jobs ... Page 7-22
- ㉑ Default of edit. Function ... Page 7-22
- ㉒ Adj. preview copy ... Page 7-23

8 To set another item, return to step 6. To complete the setting, press the ▼ or ▲ key to select "Default/back manager" ["Back to Default/manage"] and press the OK key. Press the ▼ or ▲ key to select "End".

(3) Setting of each item

● **Machine default**

① **Paper width adjustment**

1 Press the ▼ or ▲ key to select the desired paper source.

(Inch)

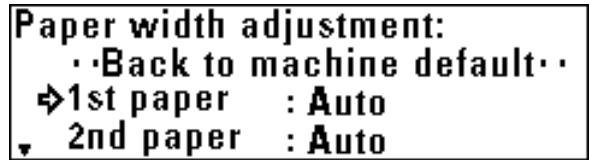

(Metric)

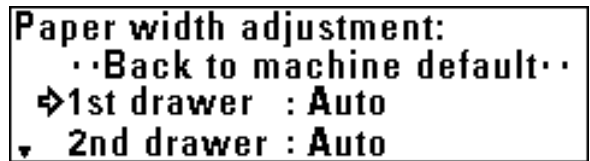

2 Press the OK key.

3 To enable automatic detection, press the ▼ or ▲ key to select "Auto". To enter the paper width, select "Input width(# key)".

(Inch)

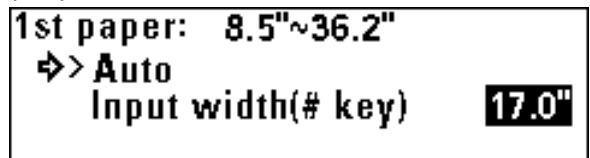

(Metric)

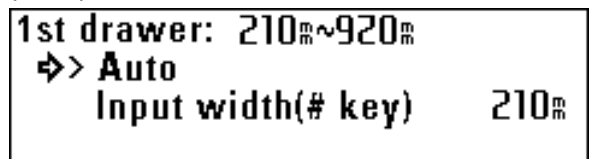

* If "Input width(# key)" is selected, use the numeric keys to enter the paper width between 8.5" and 36.2" [210 mm and 920 mm].

4 Press the OK key.

5 Press the ▼ or ▲ key to select "Back to machine default".

6 Press the OK key. The machine will return to the machine default setting screen.

② Paper working

1 To enable registration of paper material for each paper source, press the ▼ or ▲ key to select "ON".

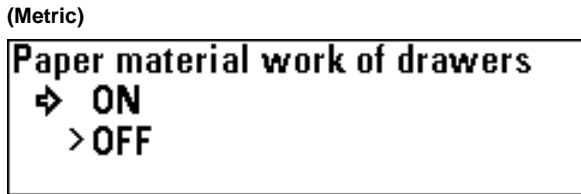
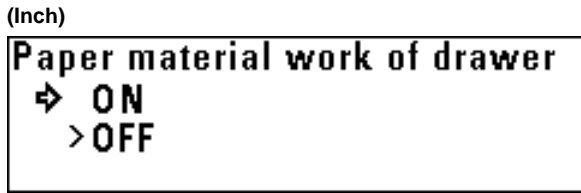

2 Press the OK key. The machine will return to the machine default setting screen.

③ Paper material adjustment

NOTE

If "② Paper working" is set to "OFF", this item cannot be set.

1 Press the ▼ or ▲ key to select a paper source.

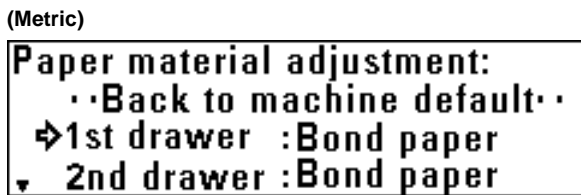
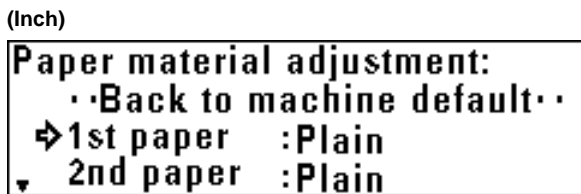

2 Press the OK key.

3 Press the ▼ or ▲ key to select a paper material.

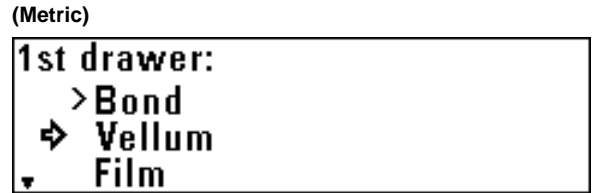
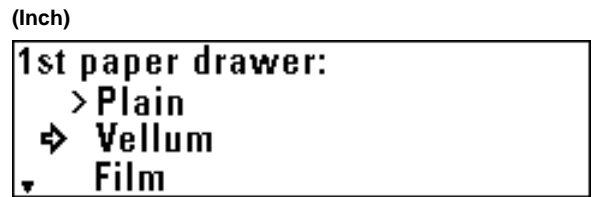

4 Press the OK key.

5 Press the ▼ or ▲ key to select "Back to machine default".

6 Press the OK key. The machine will return to the machine default setting screen.

④ Roll end adjustment

1 Press the ▼ or ▲ key to select a paper material.

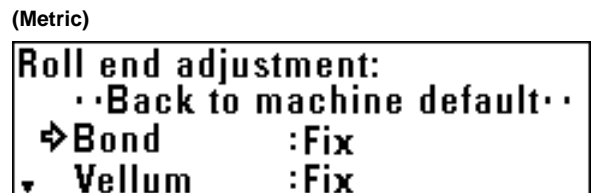
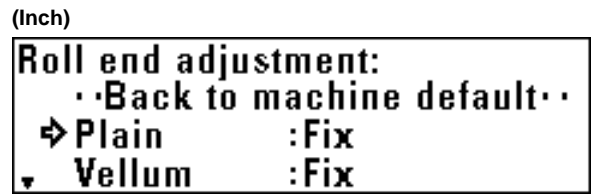

2 Press the OK key.

- 3 Concerning the paper end that is fixed or not fixed to the roll core, press the ▼ or ▲ key to select "Fix" or "Unfix".

(Inch)

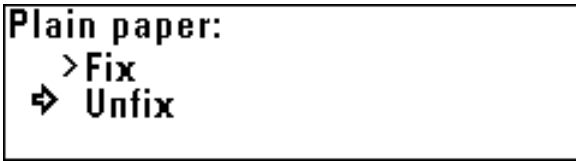

(Metric)

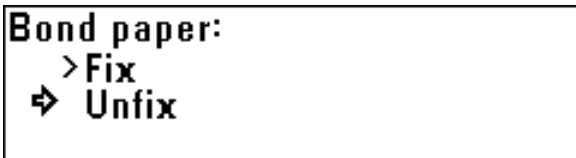

- 4 Press the OK key.

- 5 Press the ▼ or ▲ key to select "Back to machine default".

- 6 Press the OK key. The machine will return to the machine default setting screen.

⑤ Display contrast

- 1 Press the ▼ or ▲ key to set the contrast of the display. A larger value indicates lighter contrast and a smaller value indicates darker contrast.

(Inch)

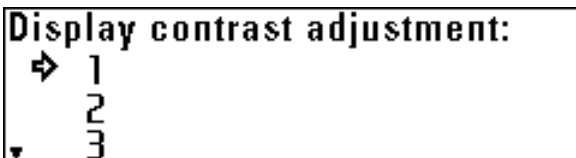

(Metric)

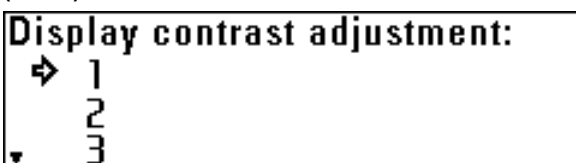

- 2 Press the OK key. The machine will return to the machine default setting screen.

⑥ Orig.eject direct

- 1 Press the ▼ or ▲ key to select the ejection location for originals.

(Inch)

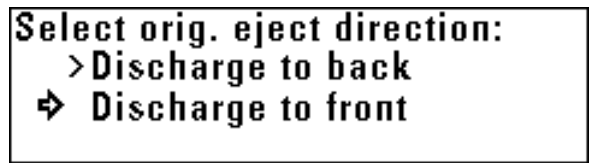

(Metric)

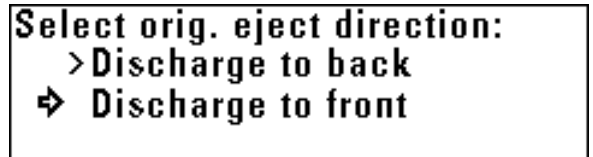

- 2 Press the OK key. The machine will return to the machine default setting screen.

⑦ Auto Clear Timer [Auto clear]

- 1 To enable the auto clear function, press the ▼ or ▲ key to select "ON".

(Inch)

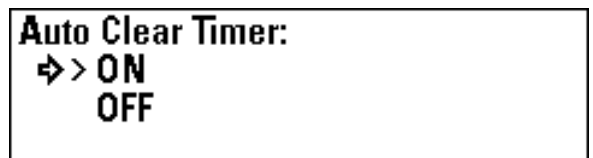

(Metric)

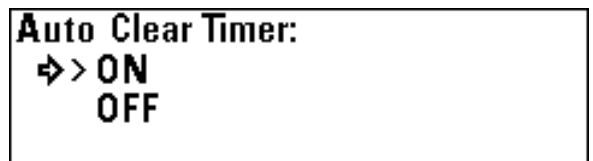

- 2 Press the OK key. The machine will return to the machine default setting screen.

⑧ Auto Shut-off Time

- 1 Press the ▼ or ▲ key to select the desired auto shut-off mode.
* If a printer/scanner controller (option) is installed, "Sleep mode" will be displayed.

(Inch)



(Metric)



- 2 Press the OK key. The machine will return to the machine default setting screen.

⑨ Timer Set

NOTE

- If "⑦ Auto Clear Timer" ["Auto clear"] is set to "OFF", the auto clear time cannot be set.
- If "⑧ Auto Shut-off Time" is set to "OFF", the auto shut-off time cannot be set.
- When setting the auto preheat time, do not set a longer time than the auto shut-off time.

- 1 Press the ▼ or ▲ key to select the function for which the timer is to be set.

(Inch)

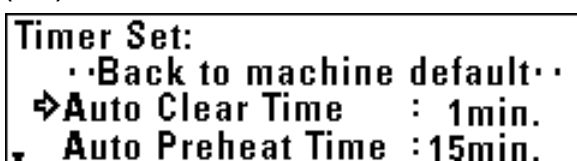

(Metric)

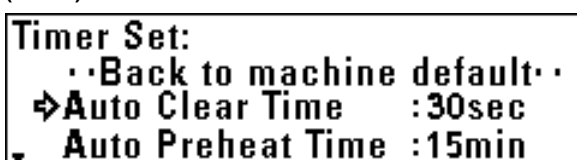

- 2 Press the OK key.

- 3 Press the ▼ or ▲ key to set the time that elapses before the selected function is activated.
> If "Auto Clear Time" ["Auto clear"] has been selected, set the time to from 30 seconds to 5 minutes.

(Inch)



(Metric)

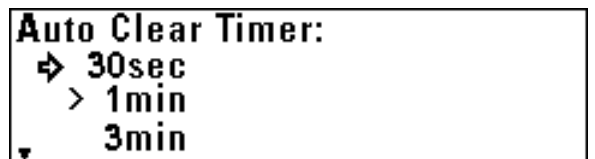

- > If "Auto Preheat Time" has been selected, set the time to from 5 minutes to 45 minutes.

(Inch)



(Metric)

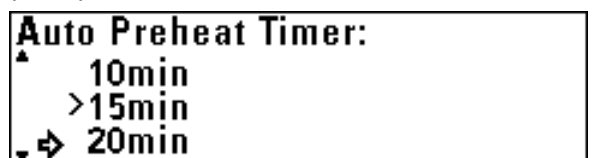

- > If "Auto Shutoff Time" ["Auto shut-off time"] has been selected, set the time to from 15 minutes to 120 minutes.

(Inch)

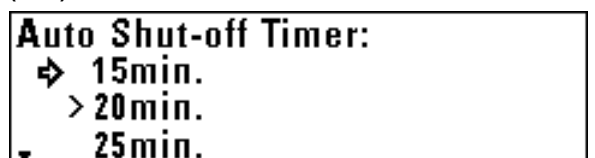

(Metric)

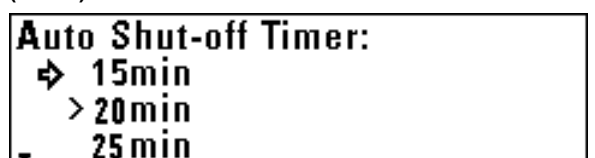

4 Press the OK key.

5 Press the ▼ or ▲ key to select “Back to machine default”.

6 Press the OK key. The machine will return to the machine default setting screen.

⑩ Copy size adjustment

1 Press the ▼ or ▲ key to select a paper material.

(Inch)

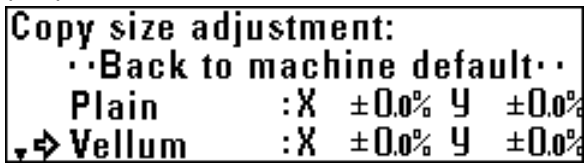

(Metric)

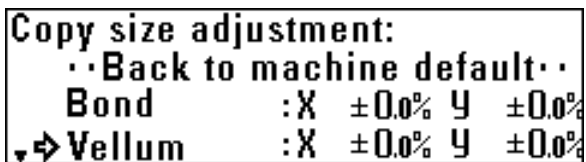

2 Press the OK key.

3 Press the ◀ or ▶ key to select the copy size in the length-wise direction (X).
The value can be set to from -3.0% to + 3.0%.

4 Press the ▼ or ▲ key.

5 Press the ▼ or ▲ key to select the copy size in the widthwise direction (Y).
The value can be set to from -3.0% to + 3.0%.

6 Press the OK key.

7 Press the ▼ or ▲ key to select “Back to machine default”.

8 Press the OK key. The machine will return to the machine default setting screen.

⑪ Fusing temperature [Set fixing temp.]

1 Press the ▼ or ▲ key to select a paper material.

(Inch)

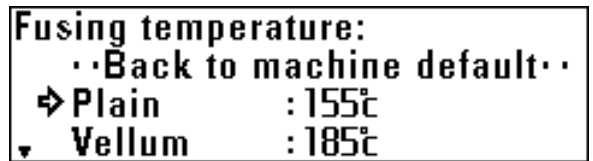

(Metric)

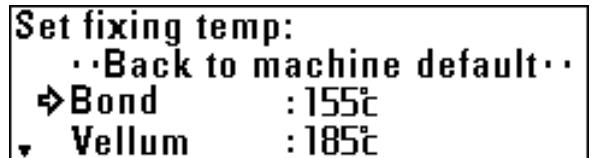

2 Press the OK key.

3 Press the ▼ or ▲ key to select the fixing temperature for each paper material.
> If “Plain” [“Bond paper”] has been selected, select from 145°C, 155°C, and 165°C.

(Inch)

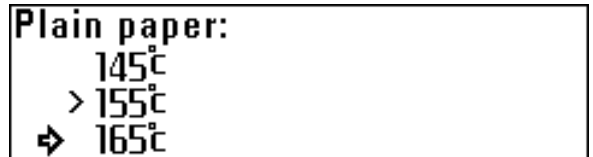

(Metric)

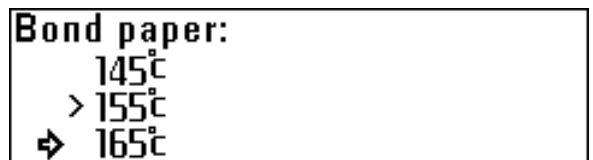

> If “Vellum” has been selected, select from 165°C, 175°C, and 185°C.

> If “Film” has been selected, select from 150°C, 160°C, and 170°C.

> If “Custom” has been selected, the temperature that has been set for custom paper material will be displayed.

4 Press the OK key.

5 Press the ▼ or ▲ key to select “Back to machine default”.

6 Press the OK key. The machine will return to the machine default setting screen.

12 Custom paper adj.

1 Press the ▼ or ▲ key to select a paper material.

(Inch)

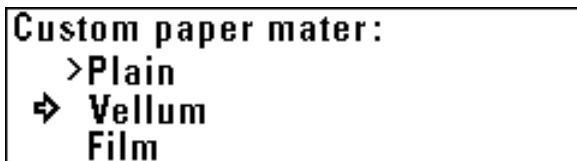

(Metric)

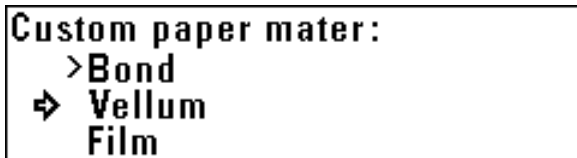

2 Press the OK key.

3 Press the ▼ or ▲ key to select the fixing temperature based on each paper material.

(Inch)

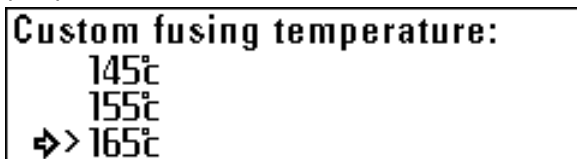

(Metric)

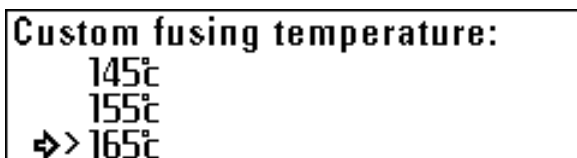

4 Press the OK key.

5 Press the ▼, ▲, ◀, and ▶ keys to set the copy size. For the method of setting, see “10 Copy size adjustment” on page 7-2.

6 Press the OK key. The machine will return to the machine default setting screen.

13 Standard size set

1 Press the ▼ or ▲ key to select the type of standard size. For an inch machine, select “architecture” or “engineer”. For a metric machine, select “A sizes” or “B sizes”.

(Inch)

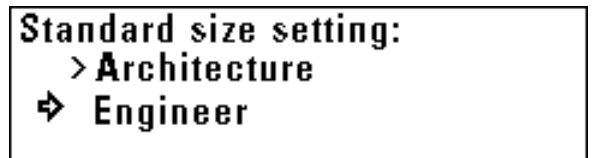

(Metric)

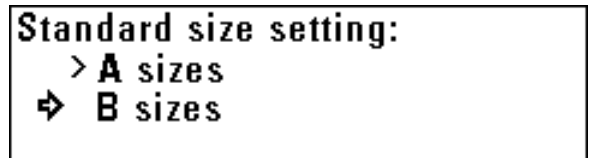

2 Press the OK key. The machine will return to the machine default setting screen.

14 Auto roll over

1 To enable auto roll change, press the ▼ or ▲ key to select “ON”.

(Inch)

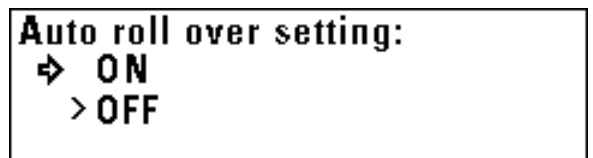

(Metric)

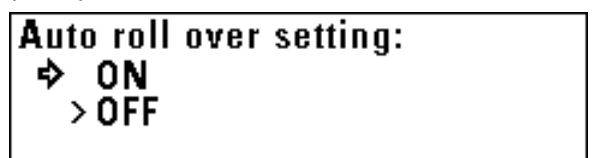

2 Press the OK key. The machine will return to the machine default setting screen.

⑮ Management # [Management code change]

1 Use the numeric keys to enter a four digit password.

(Inch)

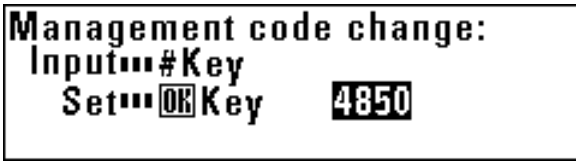

(Metric)

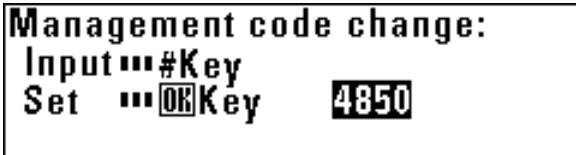

2 Press the OK key. The machine will return to the machine default setting screen.

● Items that can be selected from copy default

① Auto rotation mode

1 To enable auto rotation copy, press the ▼ or ▲ key to select "ON".

(Inch)

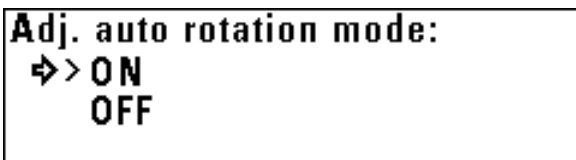

(Metric)



2 Press the OK key. The machine will return to the copy default setting screen.

② Zoom step

1 Press the ▼ or ▲ key to select a zoom step: 1% or 0.1%.

(Inch)

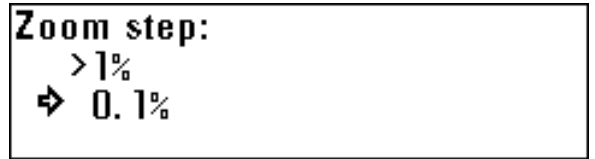

(Metric)

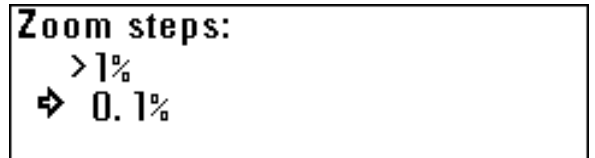

2 Press the OK key. The machine will return to the copy default setting screen.

③ Zoom register

1 Press the ▼ or ▲ key to select a user No.

(Inch)

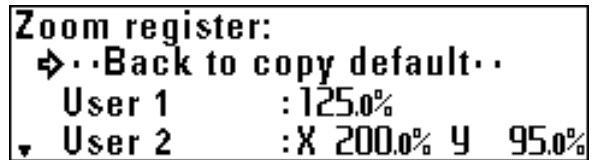

(Metric)

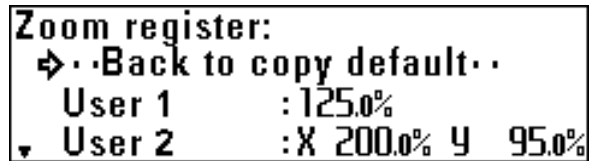

2 Press the OK key.

3 Press the ▼ or ▲ key to select “Zoom” or “XY Zoom”.

(Inch)



(Metric)



4 Press the OK key.
If “Zoom” has been selected, proceed to the next step. If “XY Zoom” has been selected, proceed to step 6.

5 Press the ◀ or ▶ key or the numeric keys to select the desired magnification ratio. The ratio can be set to from 25.0% to 400.0%. Proceed to step 9.

(Inch)

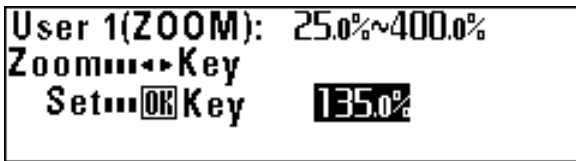

(Metric)

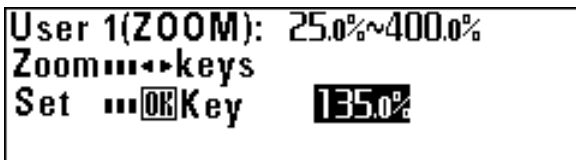

6 Press the ◀ or ▶ key or the numeric keys to select the desired magnification ratio in paper lengthwise direction (X). The ratio can be set to from 25.0% to 400.0%.

(Inch)



(Metric)

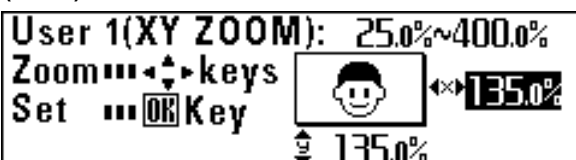

7 Press the ▼ or ▲ key.

8 Press the ▼ or ▲ key or the numeric keys to select the desired magnification ratio in paper widthwise direction (Y). The ratio can be set to from 25.0% to 400.0%.

9 Press the OK key.

10 Press the ▼ or ▲ key to select “Back to copy default”.

11 Press the OK key. The machine will return to the copy default setting screen.

④ Cut size register

1 Press the ▼ or ▲ key to select a user No.

2 Press the OK key.

3 Use the numeric keys to enter the cut length. Select a value from 11" to 236.2" [279 mm to 6000 mm].

(Inch)

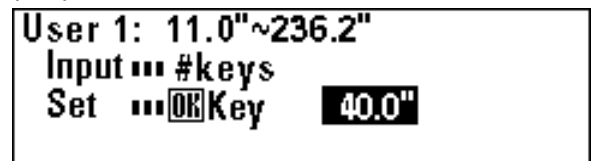

(Metric)

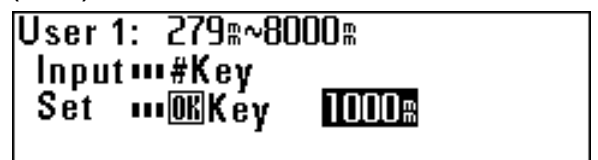

4 Press the OK key.

5 Press the ▼ or ▲ key to select “Back to copy default”.

6 Press the OK key. The machine will return to the copy default setting screen.

⑥ Exposure step [Exposure steps]

1 Press the ▼ or ▲ key to select the desired copy contrast mode.

(Inch)

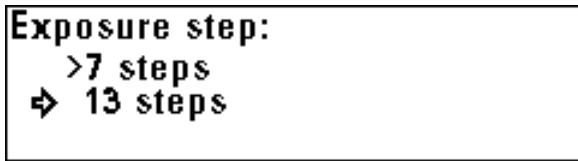

(Metric)



2 Press the OK key. The machine will return to the copy default setting screen.

⑥ Auto/Manual exp.

1 Press the ▼ or ▲ key to select the desired copy contrast mode.

(Inch)

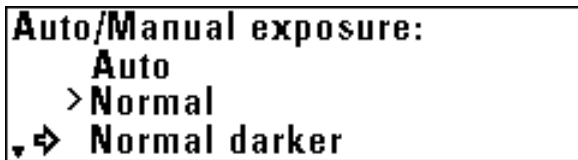

(Metric)

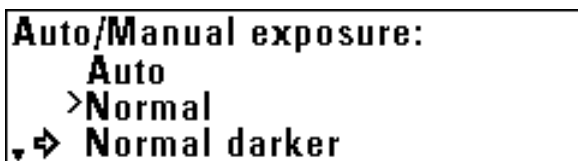

2 Press the OK key. The machine will return to the copy default setting screen.

⑦ Default exposure

1 Press the ▼ or ▲ key to select the desired exposure indicator position.

(Inch)

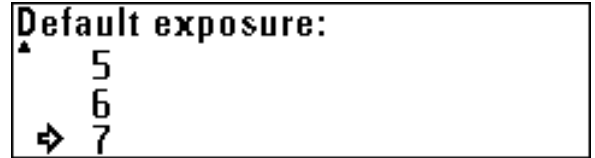

(Metric)

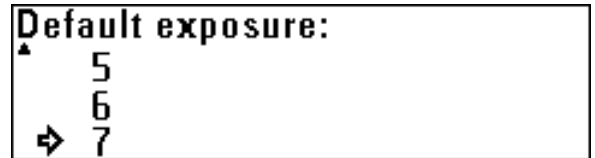

2 Press the OK key. The machine will return to the copy default setting screen.

⑧ Exposure adj.

1 Press the ▼ or ▲ key to select an original mode.

(Inch)

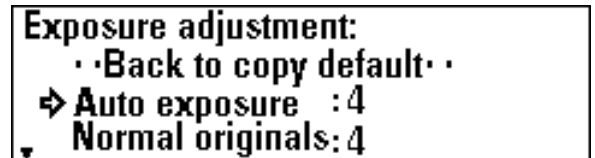

(Metric)

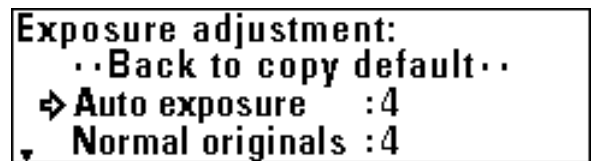

2 Press the OK key.

- 3** Press the ▼ or ▲ key to select the desired copy contrast. A larger value indicates a darker exposure level.

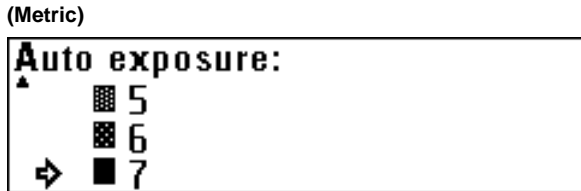
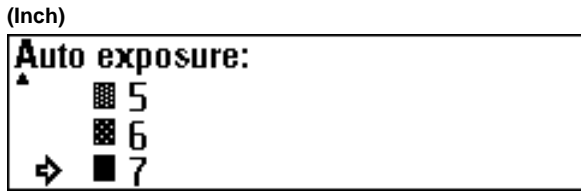

- 4** Press the OK key.

- 5** Press the ▼ or ▲ key to select "Back to copy default".

- 6** Press the OK key. The machine will return to the copy default setting screen.

⑨ Standard drawer

- 1** Press the ▼ or ▲ key to select the desired paper source.

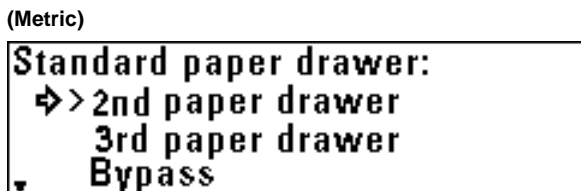
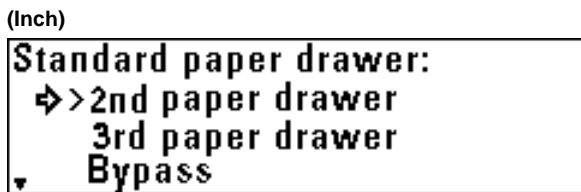

- 2** Press the OK key. The machine will return to the copy default setting screen.

⑩ Auto select set

- 1** Press the ▼ or ▲ key to select the desired copy mode.

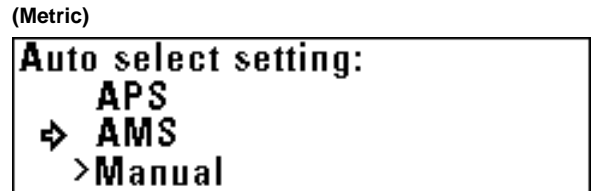
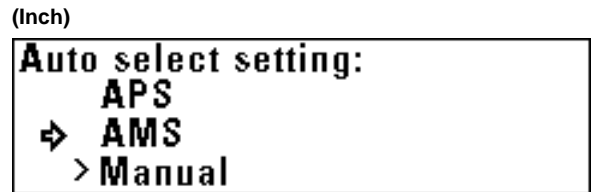

- 2** Press the OK key. The machine will return to the copy default setting screen.

⑪ AMS mode

- 1** To set the AMS mode as the default setting, press the ▼ or ▲ key to select "ON".

If this item is set to "OFF", the default setting will be the preset magnification ratio.

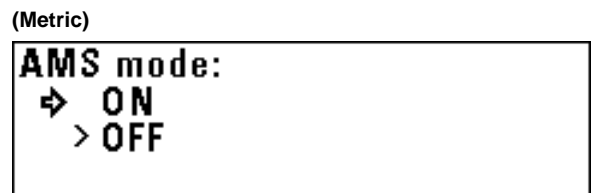
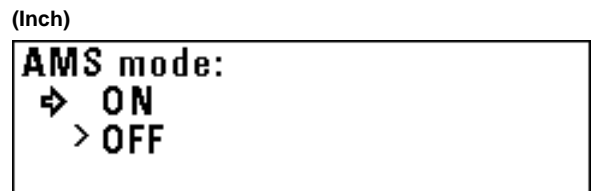

- 2** Press the OK key. The machine will return to the copy default setting screen.

⑫ Method copy start

- 1 Press the ▼ or ▲ key to select the desired copy start method.

(Inch)



(Metric)

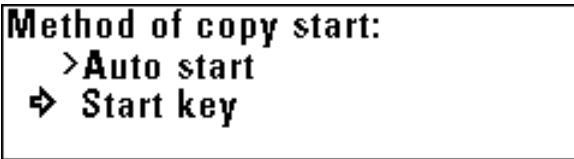

- 2 Press the OK key. The machine will return to the copy default setting screen.

⑬ Start late time

NOTE

- If “⑫ Method copy start” is set to “Start key”, this item cannot be set.

- 1 Press the ▼ or ▲ key to select the desired delay time for auto start.
The time can be set to from 0.5 second to 5 seconds.

(Inch)

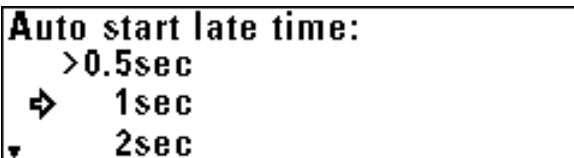

(Metric)

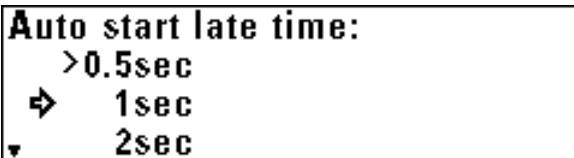

- 2 Press the OK key. The machine will return to the copy default setting screen.

⑭ Paper cut [Select cut. Method]

NOTE

- The sizes displayed depend on the setting of “⑬ Standard size set” of the machine default setting.

- 1 Press the ▼ or ▲ key to select the desired cut size.

(Inch)



(Metric)

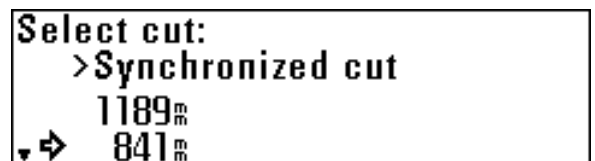

- 2 Press the OK key. The machine will return to the copy default setting screen.

⑮ Sync. Cut length

- 1 To display the synchronized cut length, press the ▼ or ▲ key to select “ON”.

(Inch)

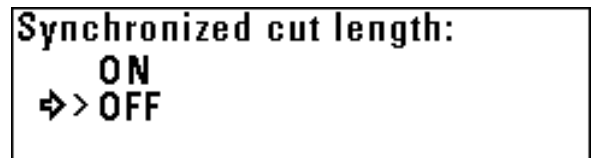

(Metric)

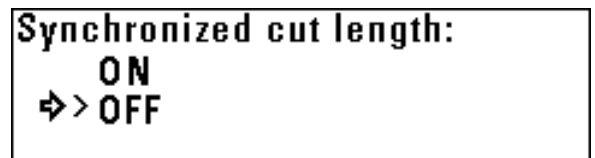

- 2 Press the OK key. The machine will return to the copy default setting screen.

16 Delete memory

- 1 To delete the image, press the ▼ or ▲ key to select "Delete". To display a confirmation screen, select "Check data of repeat copy".

(Inch)

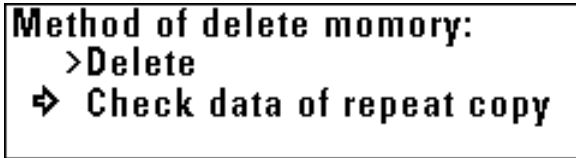

(Metric)

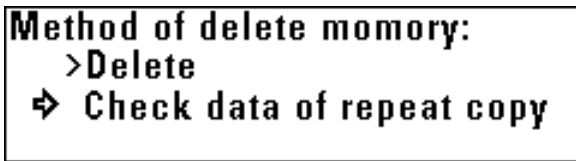

- 2 Press the OK key. The machine will return to the copy default setting screen.

17 Permit repeat

- 1 Press the ▼ or ▲ key to select "Permit", "Code number" ["Id-code"] or "Unpermit".

(Inch)

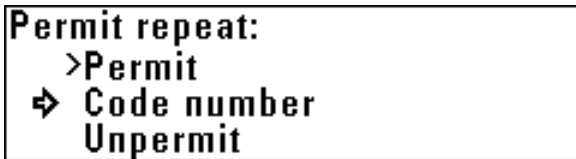

(Metric)

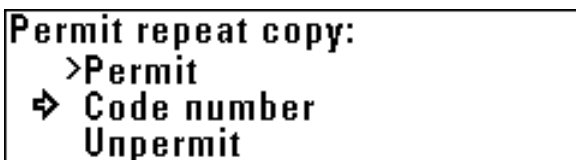

- 2 Press the OK key. The machine will return to the copy default setting screen.

18 Change repeat # [Repeat code change]

NOTE

- If "17 Permit repeat" is set to "Permit" or "Unpermit", this item cannot be set.

- 1 Use the numeric keys to enter the repeat copy code (four digits).

(Inch)

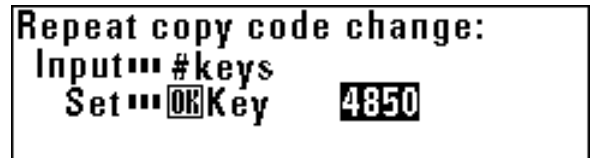

(Metric)

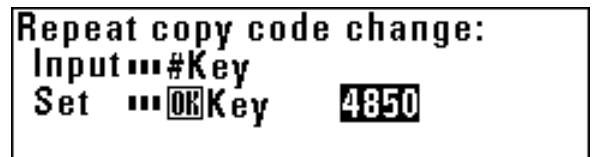

- 2 Press the OK key. The machine will return to the copy default setting screen.

19 Memory compress

- 1 Press the ▼ or ▲ key to select the desired image compression ratio.

(Inch)



(Metric)



- 2 Press the OK key. The machine will return to the copy default setting screen.

⑳ Maximum Jobs

1 Press the ▼ or ▲ key to select the maximum number of jobs.

(Inch)

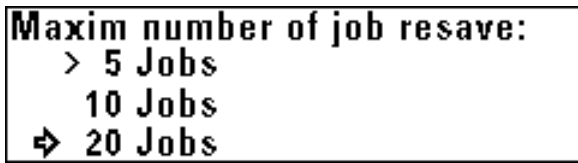

(Metric)

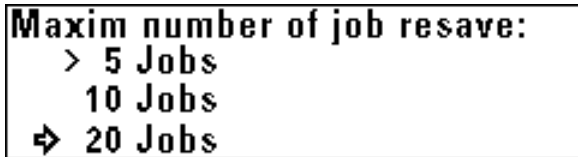

2 Press the OK key. The machine will return to the copy default setting screen.

㉑ Default of edit. Function

1 Press the ▼ or ▲ key to select the desired editing function.

2 Press the OK key.

- If "Image shift up/down" has been selected, proceed to the next step.
- If "Image shift L/R" has been selected, proceed to step 4.
- If "Leading edge" has been selected, proceed to step 5.
- If "Trailing edge" has been selected, proceed to step 6.
- If "Border erase" has been selected, proceed to step 7.

3 Press the ▼ or ▲ key to select the desired image shift direction and use the numeric keys to enter the shift amount. Set the shift amount to from 8.0" up to 8.0" down [200 mm up to 200 mm down]. Proceed to step 8.

(Inch)



(Metric)



4 Press the ◀ or ▶ key to select the desired image shift direction and use the numeric keys to enter the shift amount. Set the shift amount to from 8.0" left to 8.0" right [200 mm left to 200 mm right]. Proceed to step 8.

(Inch)



(Metric)



5 Press the ▼ or ▲ key to select "+" or "-" and use the numeric keys to enter the margin amount. Set the margin amount to from -8.0" to +8.0" [-200 mm to +200 mm]. Proceed to step 8.

(Inch)

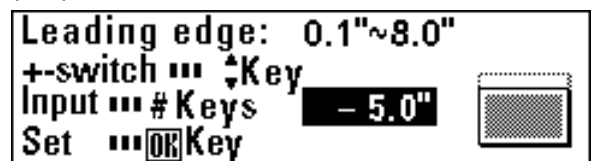

(Metric)



- 6** Press the ▼ or ▲ key to select “+” or “-” and use the numeric keys to enter the margin amount.
Set the margin amount to from -8.0" to +8.0" [-200 mm to +200 mm].
Proceed to step 8.

(Inch)

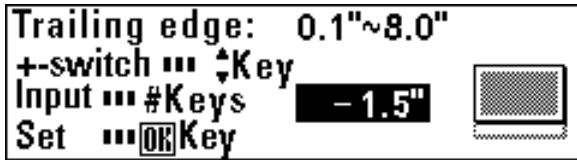

(Metric)



- 7** Use the numeric keys to enter the border erase amount.
Set the border erase amount to from 0" to +8.0" [0 mm to +200 mm].
Proceed to step 8.

(Inch)

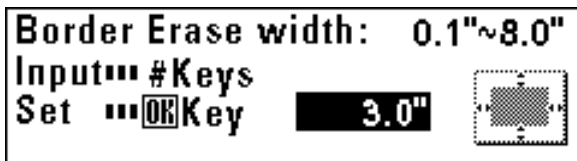

(Metric)

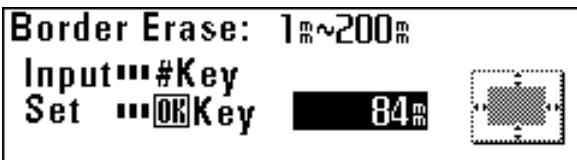

- 8** Press the OK key.

- 9** Press the ▼ or ▲ key to select “Back to copy default”.

- 10** Press the OK key. The machine will return to the copy default setting screen.

Adj. preview copy

- 1** Press the ▼ or ▲ key to select the desired preview copy type.

(Inch)



(Metric)



- 2** Press the OK key. The machine will return to the copy default setting screen.

3. Language Switching

The messages of this machine can be displayed in Japanese, American English, British English, French, Spanish, German, and Italian.

- 1 Press the */Language key.

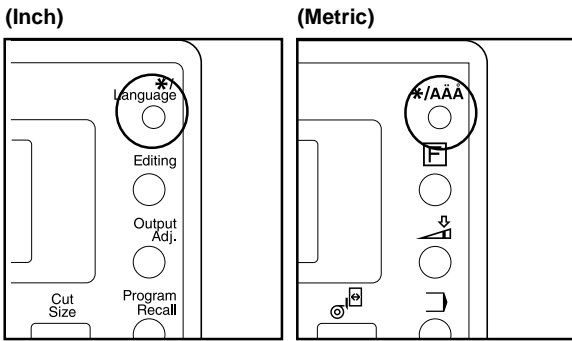

- 2 Press the ▼ or ▲ key to select "Language".

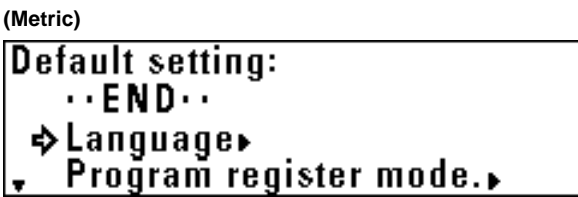
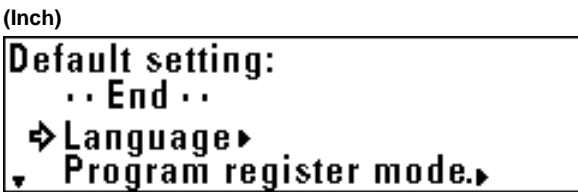

- 3 Press the OK key.

- 4 Press the ▼ or ▲ key to select the desired language.

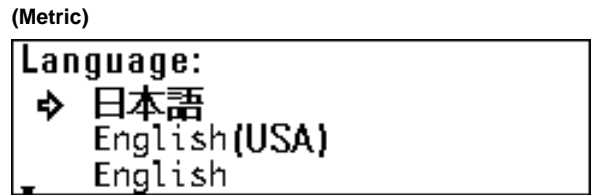
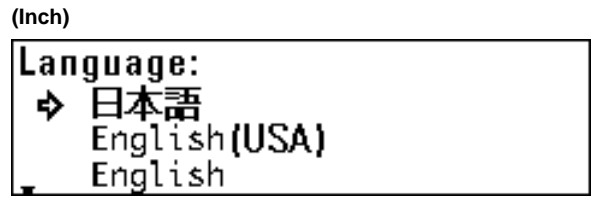

- 5 Press the OK key. Then, press the Reset key.

CHAPTER 8 TROUBLESHOOTING

1. Messages during Copying

When any message shown below appears in the message display of the operation panel, follow the appropriate procedure.

Message	Countermeasures	Page
"Close front cover."	The front cover is open. Close the front cover securely.	–
"Close eject cover." ["Close output cover."]	The eject cover is open. Close the eject cover securely.	–
"Push and close original table."	The main body of the machine is open. Grasp the main body release lever with both hands and push the original table to close the machine.	–
"Close toner cover."	The toner tank cover is open. Close the toner tank cover securely.	–
"Close right cover."	The right cover is open. Close the right cover securely.	–
"Close original holder" "Close the cover of orig. holder"	An original holder or the original leading edge cover is open. Close it securely.	–
"Paper misfeed."	A paper jam has occurred. Remove the jammed paper in accordance with the message.	8-9
"Set original again"	The original has jammed. Remove the original and set it again on the original table.	8-13
"Remove original."	The original has jammed after scanning of original is complete. Remove the original.	8-13
"Place paper in drawer."	Paper in the roll unit runs out. Replace the paper roll with a new one.	3-6
"Remove remaining paper"	Paper in the roll unit runs out. Open the front cover, rewind remaining paper roll, and replace it with a new one.	3-6

CHAPTER 8 TROUBLESHOOTING

Message	Countermeasures	Page
"No roll unit" ["Roll unit is not set."]	A roll unit is not securely inserted. Open the front cover and push the roll unit in securely.	3-6
"Add Paper in X Drawer."	Paper with different width is set for interrupt copy or job reserve. Replace the paper roll.	3-6
"Check waste toner tank."	The waste toner tank is full or the tank is not properly installed. Replace it with a new tank or install the tank properly.	8-5
"Add toner to resume copying."	If this message is displayed with "Ready to copy.", copying can be performed but continuous copying is not possible. Replenish toner promptly. Copying can be performed for some time but when only this message is displayed, copying cannot be performed.	8-3
"Time for Maintenance"	Maintenance of the machine is needed. Contact your service representative.	—
"Call for service."	A problem has occurred inside the main body. See "5. Countermeasures against Call for service Message".	8-8
"Memory full"	Memory overflow has occurred. See "4. Countermeasures against Memory Overflow."	8-6
"Could not be saved."	Original images cannot be saved in memory. Copying of second original and after or repeat copy cannot be performed. See "4. Countermeasures against Memory Overflow."	8-6
"Exceeding zoom range. Reenter zoom ratio."	The magnification ratio or another setting for editing functions exceeds the specified limit. Press the OK key and then enter the value again.	—
"These functions cannot be combined."	A function or a default setting that cannot be set now is accessed. See "List of Default Setting".	7-1
"Pin code is different"	The password is not correct. Use the numeric keys to enter the correct password.	7-3
"Repeat copy code is wrong."	The repeat copy code is not correct. Use the numeric keys to enter the correct code.	7-6
"Insert key counter."	The key counter (option) is not set or not properly set. Set the counter properly.	4-1

Message	Countermeasures	Page
"Cannot change mirror in repeat copy mode." ["Cannot change mirror image in repeat copy."]	The mirror mode setting cannot be changed in repeat copying. If the mirror mode setting is changed, perform copying again from the beginning.	6-4
"Shortage of memory to image rotate."	A memory overflow has occurred. The image rotation and auto rotation functions consume much memory. Change the orientation of the original and copy it again.	–
"Exceeded zoom range. Cannot modify copy."	The maximum enlargement ratio for repeat copying is exceeded. Perform copying operation again to continue copying.	6-4
"Cannot repeat copy this zoom#"	A memory overflow has occurred. Reduction in repeat copying may consume much memory. Perform copying operation again to continue copying.	–
"Cannot repeat copy for this paper size"	Repeat copying cannot be performed for one of the following reasons. <ul style="list-style-type: none"> • Any page that exceeds the maximum enlargement is included. • A memory overflow due to reduction occurs. • Any page for which auto rotation cannot be performed is included. Perform copying operation again to continue copying.	6-4
"Cannot job reserve during reduce modify copy."	While repeat copying with reduction is being performed, the job reserve function may not be used. Wait until the current copy job is complete.	6-4
"Reposition original or change drawer." ["Reset original or select another paper drawer."]	Auto rotation cannot be performed. Change the orientation of the original.	–

2. Replenishing the Toner

When there is insufficient toner, the message "Add toner to resume copying." appears. If this message is displayed with "Ready to copy.", continuous copying is not possible. Although copying is possible for some time, if only the message "Add toner to resume copying." is displayed, copying is not possible. Replenish toner promptly.

When dark originals are copied continuously, since much toner is consumed at a time, the message "Replenish toner promptly." may appear even if toner is left in the machine. At this time, open and close the toner replenishing slot. Toner replenishment will be performed.

(Inch)

Ready to copy.
Add toner to resume copying 20set
 Plain
 18.0× Sync

100%

(Metric)

Ready to copy
Add toner to resume copying 20cp
 Bond
 594× Sync

100%

- 1** Remove the original loop guide and then turn the screws on both sides of the toner replenishing slot according to the marking position to open the toner replenishing slot.

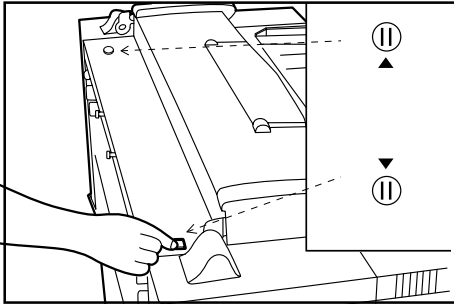

- 2** Grasp the replenishment toner bottle upside down and tap the bottom of the bottle 10 times.

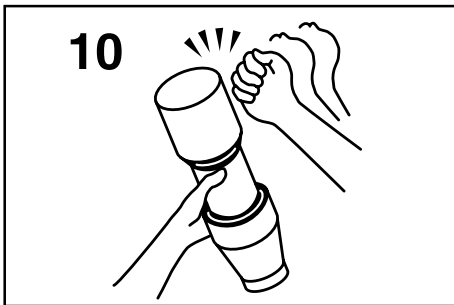

- 3** Shake the replenishment toner bottle up and down 10 times, and grasp it horizontally and shake it side to side 10 times.

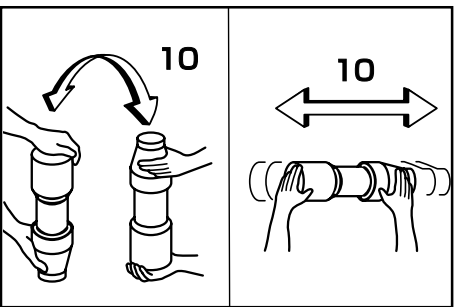

- 4** Align the ▼ portion of the toner bottle with the pin ① (metal protrusion) of the opening to insert the bottle into the opening as shown in the illustration.

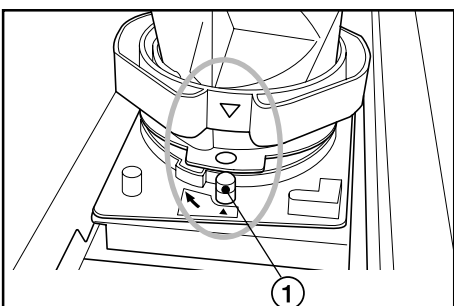

- 5** While pressing the toner bottle down, turn it clockwise by 90 degrees. Toner will be replenished.

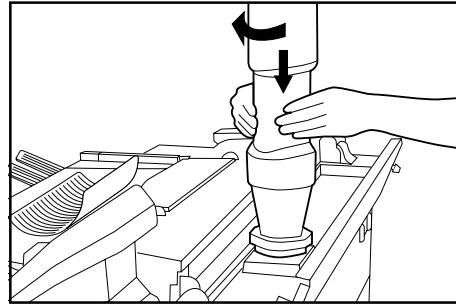

- 6** Tap the side of the toner bottle 7 or 8 times to drop the toner remaining.

- 7** While pressing the toner bottle down, turn it to the original position and gently remove it.

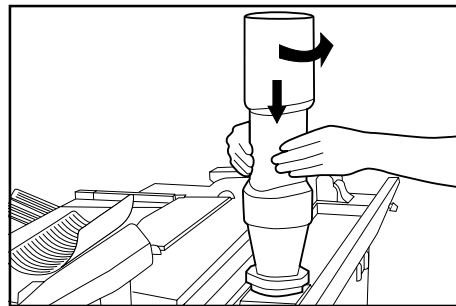

- 8** Close the toner replenishing slot and turn the toner replenishing slot screws to the location shown in the illustration to fix it. Then reattach the original loop guide.

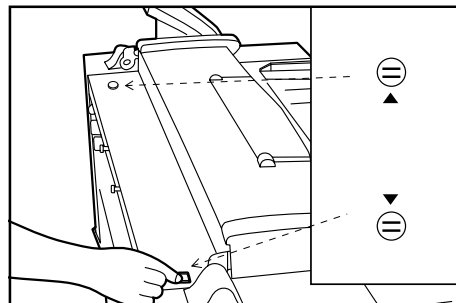

⚠ CAUTION
Do not incinerate toner and toner containers. Dangerous sparks may cause burn.

3. Replacing the Waste Toner Tank

When the waste toner tank is full, the message “Check waste toner tank.” appears and copying is not possible. Replace the tank with a new waste toner tank.

(Inch)



(Metric)



- 1 Open the right cover and remove the waste toner tank by pulling it out toward you.

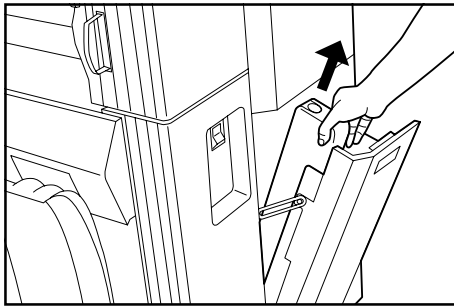

- 2 Seal the waste toner tank opening with the seal located on it.

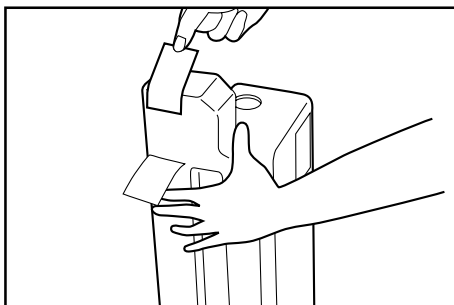

- 3 Set a new waste toner tank into the machine.

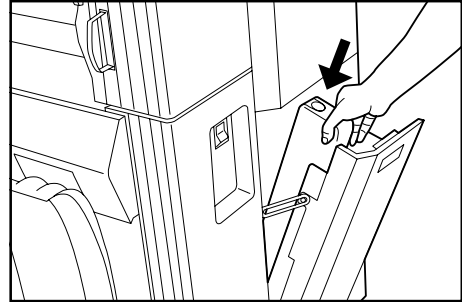

- 4 Close the right cover.

* Toner in the waste toner tank cannot be reused.

⚠ CAUTION

Do not incinerate toner and toner containers. Dangerous sparks may cause burn.

4. Countermeasures against Memory Overflow

This machine stores image data in memory and then performs copying. Since the memory capacity is limited, memory overflow may occur during copying and the following messages may appear.

If “**Ⓢ** Memory compress” of the default setting is set to “Standard-compression “ [“Standard”]” from Non-compression” or to “High-compression “ [“Condensation”]” from “Standard-compression “ [“Standard”]”, the image data capacity in the memory can be increased. If the compression ratio is set to a higher level, however, halftone (gray) images may be deteriorated. (Page 7-6)

* If memory overflow occurs frequently, addition of memory is recommended. Contact a dealer of our products.

If the message “Could not be saved.” appears:

This message may appear when copying is performed while the original is being scanned in normal copying. The overall image data could not be saved in memory.

If the number of copies is more than 1, only one copy will be output. Repeat copy is not possible.

If the message “Memory full” appears:

This message may appear when scanning of original is performed before copying for using the sort copy, editing functions, job reserve or interrupt copy.

If memory overflow has occurred in job reserve or interrupt copy, wait until the current output is complete. If memory overflow has occurred in sort copy, reduce the number of originals.

(Inch)



(Metric)



(Inch)

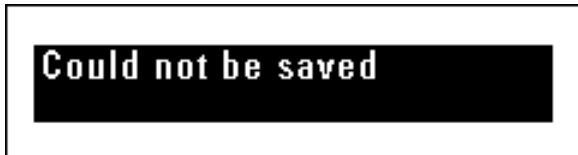

(Metric)



1 Press the OK key. A selection screen for original ejection direction will appear.

2 Press the ▼ or ▲ key to select the original ejection direction.

(Inch)

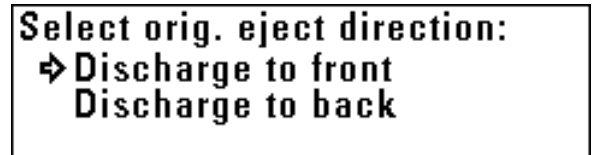

(Metric)

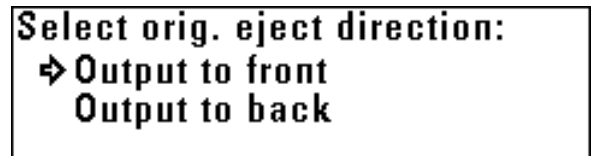

3 Press the OK key. The original will be ejected.

If memory overflow has occurred when the first original was being scanned, the image data of the scanned original will be deleted.

If some originals have been scanned in sort copy or the like, proceed to the next step.

4 A confirmation screen for output of scanned originals will appear.

Press the ▼ or ▲ key to select "Yes" or "No".

> If "No" is selected, output will be canceled.

(Inch)

Print out memorized image:
 ⇒ Yes
 No

(Metric)

Print out stored image:
 ⇒ Yes
 No

5 Press the OK key.

> If "Yes" has been selected, proceed to the next step.

6 A screen for checking or changing the number of copies will appear.

Check the number of copies and press the Start key.

To change the number of copies, use the numeric keys to enter the number and press the Start key. The images of the original that has caused memory overflow will be discarded and only the images that have been scanned normally will be output.

(Inch)

Check and correct sets 01
Print start Start Key 1Set

(Metric)

Check and correct sets 01
Print start Start key 1st

5. Countermeasures against Call for service Message

If the message "Call for service" appears, the machine has detected abnormal conditions. Stop use of this machine and follow the procedure below.

(Inch)



(Metric)



- 1 Pull the main body release lever to open the main body and then close the main body.

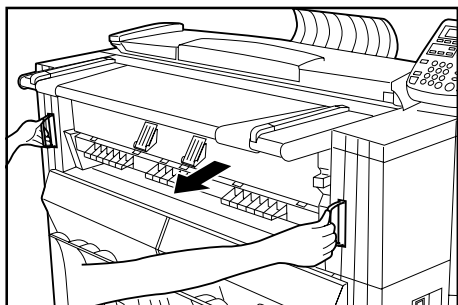

- 2 If the same message remains, make a note of the displayed error code (C xxxx in the example above).

- 3 Turn the main power switch off(O) and disconnect the power cord.

- 4 Contact your service representative. At this time, report the error code above.

6. When Paper or an Original Jams

When paper or an original jams, copying will stop and a message indicating a jam will appear. Keep the main power switch on (1) and remove the jammed paper in accordance with the message.

(1) Jam location display

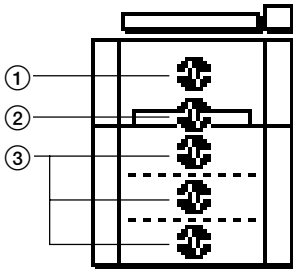

- ① Jam in the machine
- ② Jam in the bypass slot (Page 8-11)
- ③ Jam in the paper feed section (Page 8-11)
- Jam in the original cover (Page 8-13)

(2) Cautions

⚠ WARNING

High voltage is present in the charger section. Take sufficient care when working in this area, as there is a danger of electrical shock.

⚠ CAUTION

The copier's fixing unit is extremely hot. Take sufficient care when working in this area, as there is a danger of getting burned.

- Do not reuse any paper that has jammed.
- If the jammed paper tears during removal, make sure not to leave any pieces inside the machine as this would cause another jam.
- After removal of jammed paper or original, warm up will begin, the message will go out, and the machine will return to the settings before the jam has occurred.

(3) Removal procedure

- ① If "Paper misfeed. Press "Cut paper" key." or "Paper misfeed. Pull out original table." appears:
Paper has jammed in the machine. Perform the following procedure to remove the jammed paper.

(Inch)

**Paper misfeed
Press "Cut paper" key.**



(Metric)

**Paper misfeed
Press "cut paper" key**



(Inch)

**Paper misfeed
Pull out
original table**



(Metric)

**Paper misfeed
Pull out
original table**



- 1** If "Press "Cut paper" key." appears, press the Roll Cut key.

IMPORTANT

- Do not open any cover before pressing the Roll Cut key.

- 2** Grasp the main body release lever and pull it toward you. The main body will be opened.

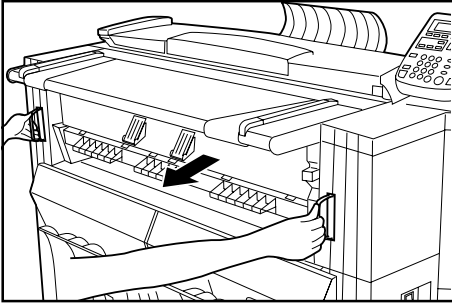

⚠ WARNING

High voltage is present in the charger section. Take sufficient care when working in this area, as there is a danger of electrical shock.

⚠ CAUTION

The copier's fixing unit is extremely hot. Take sufficient care when working in this area, as there is a danger of getting burned.

- 3** If the jammed paper is seen, pull it out.

* If it is difficult to pull it out, do not pull too hard but simply proceed to the next step.

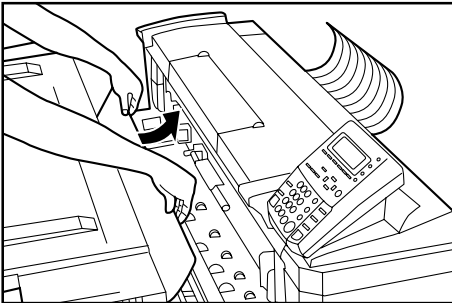

- 4** Turn the transport knob counterclockwise. Paper will be transported.



- 5** If the paper is seen, remove it from inside the machine.

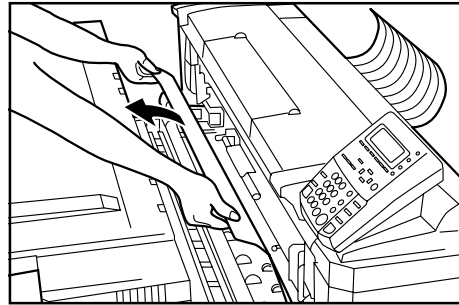

- 6** Push the ejection release lever toward you. The ejection cover will be opened.

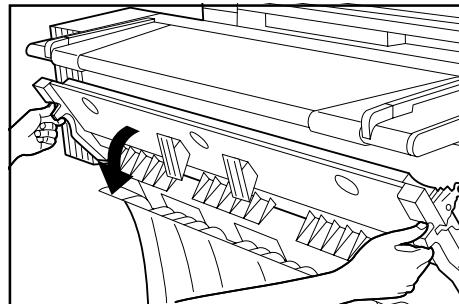

⚠ CAUTION

The copier's fixing unit is extremely hot. Take sufficient care when working in this area, as there is a danger of getting burned.

- 7** Remove the jammed paper.

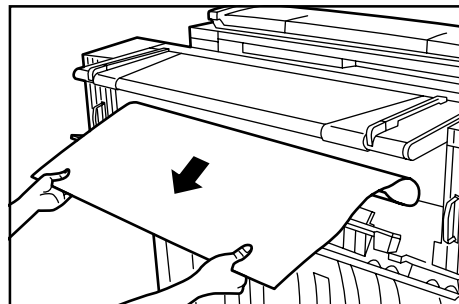

IMPORTANT

- When opening the ejection cover, be sure to pull out the original table in advance.

8 Grasp the ejection release lever and close the ejection cover.

9 Grasp the main body release lever and push the original table toward the rear side of the machine to close securely the main body.

② If "Paper misfeed. Remove paper." appears:
Paper has jammed in the bypass slot. Perform the following procedure to remove the jammed paper.

(Inch)

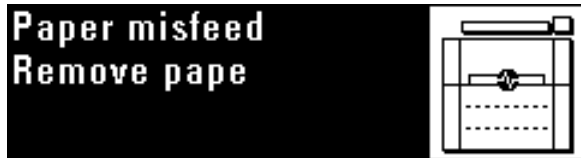

(Metric)

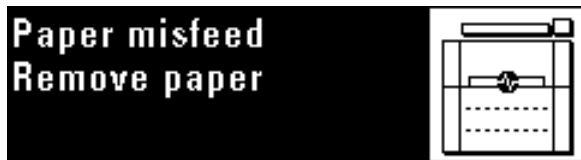

1 Pull out the paper jammed in the bypass slot toward you.
* If the jammed paper is difficult to remove, do not pull too hard but simply proceed to the next step.

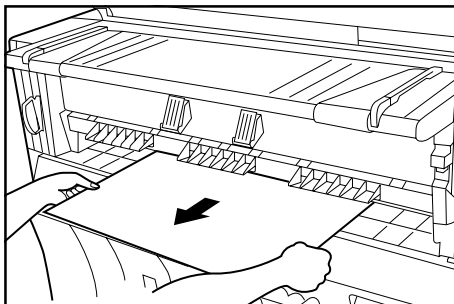

2 Grasp the main body release lever and pull it toward you. The main body will be opened.

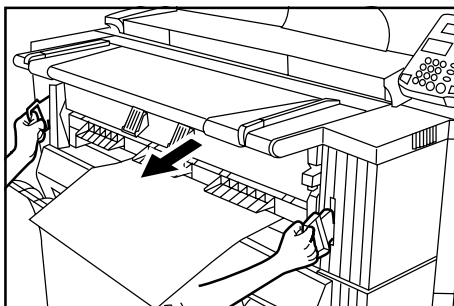

⚠ WARNING

High voltage is present in the charger section. Take sufficient care when working in this area, as there is a danger of electrical shock.

3 If the paper is seen, remove it from inside the machine.
* If the jammed paper is difficult to remove, do not pull too hard but simply proceed to the next step.

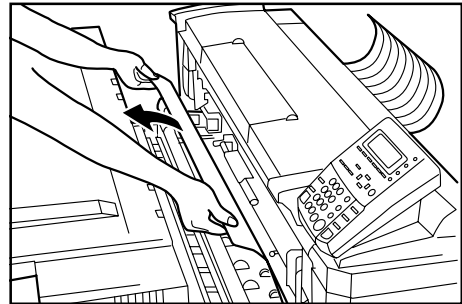

4 Grasp the main body release lever and push the original table toward the rear side of the machine to close securely the main body.

③ If "Paper misfeed. Open front cover." appears:
Paper roll has jammed in the indicated paper source. Perform the following procedure to remove the jammed paper.

(Inch)

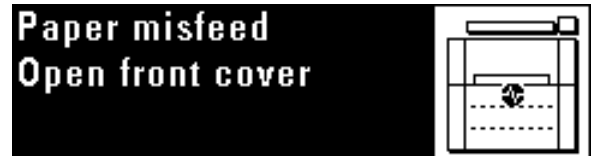

(Metric)

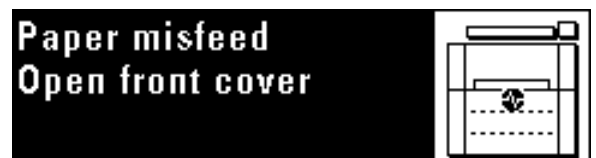

- 1** Open the front cover.

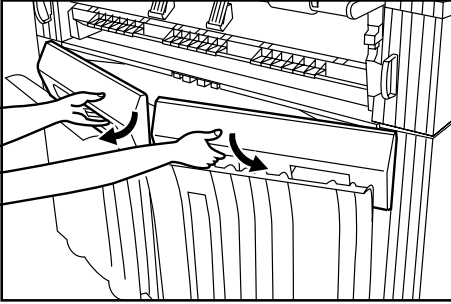

- 2** Grasp the handles (A) of the roll unit to unlock the unit and pull out the roll unit until it stops.

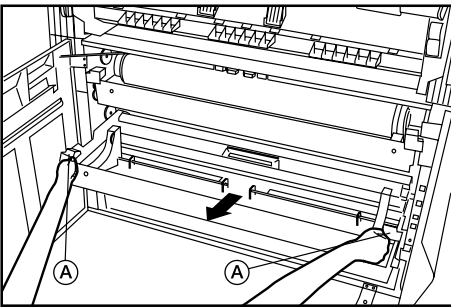

- 3** Grasp the flange and rewind the paper roll.

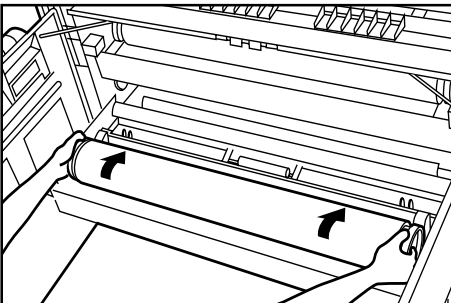

- 4** If there is any wrinkled or folded area, remove it with a cutting knife or scissors.

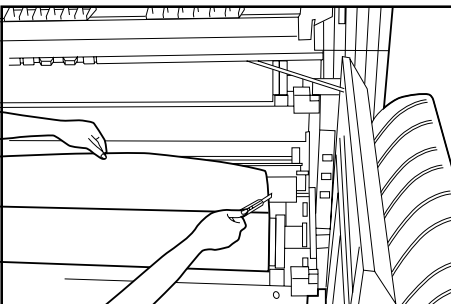

- 5** Grasp both of the paper roll insertion latches (3) and open the paper roll insertion cover (4).

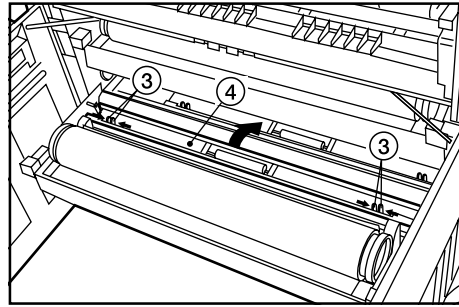

- 6** Insert the leading edge of the paper back under the paper roll insertion guide and pull the edge out approximately 1/2" [10 mm] from the guide as shown in the illustration.

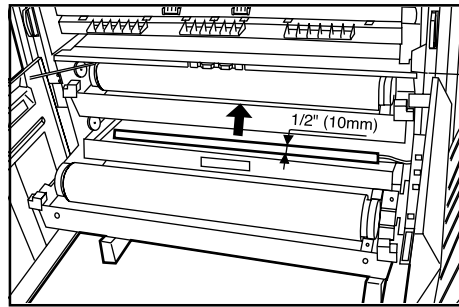

- 7** Grasp both of the paper roll insertion latches and close the paper roll insertion cover.

IMPORTANT

- If the paper roll that has been set is slack, grasp the flange and rewind the paper roll to clear the slack. If not, paper may be fed obliquely.

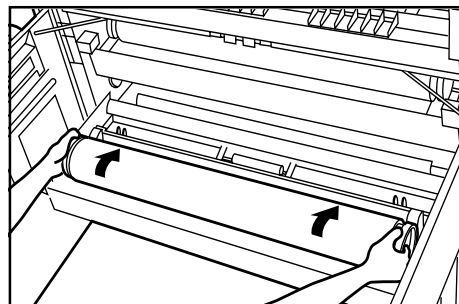

8 Push the roll unit securely back into the machine.

9 Close the front cover.

10 If the leading edge of the paper is not cut straight, press the Roll Cut key.
The leading edge of the paper will be cut.

● **Original jam in the original cover**

If an original has jammed in the original cover, the following message will appear. Perform the following procedure to remove the jammed original. If the message "Set original again" appears, reset the original.

(Inch)

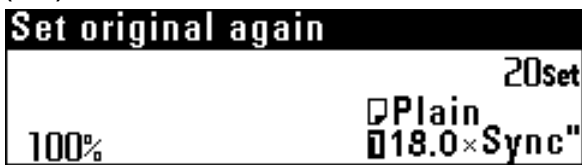

(Metric)



(Inch)

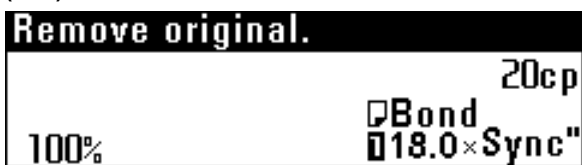

(Metric)

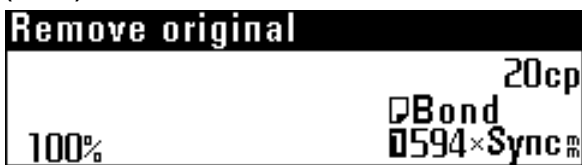

1 Grasp the original cover with both hands and open them.

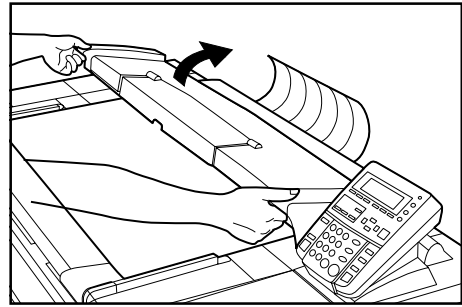

2 Remove the jammed original without tearing it.

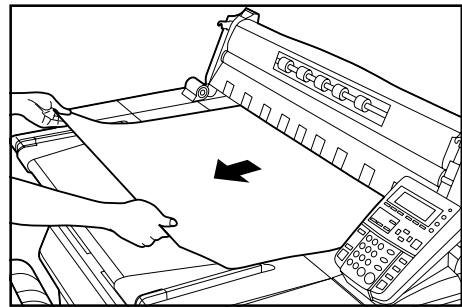

3 Gently close the original cover.

7. Troubleshooting

Refer to the following chart if trouble occurs. If trouble persists, contact your service representative.

TROUBLE	CHECK POINT	PROCEDURE	PAGE
The main power switch is on but nothing is displayed on the operation panel.	Is the power plug inserted securely into the outlet?	Insert the power plug securely into the outlet.	–
The original is set, but a copy is not made.	Is there a message on the operation panel?	Check the proper procedure for the displayed message and perform accordingly.	8-1
The copy is blank.	Was the original inserted face down?	Insert the original face down.	3-2
Paper jams often.	Are there wrinkles or folds in the paper?	Remove the portion of the paper roll that contains the wrinkles or folds.	8-12
	Is there any jammed paper or are there other pieces of paper remaining inside the machine?	Remove them by following the appropriate procedure.	8-9
	Is the paper setting method proper?	Check the paper setting method.	3-6
	Is vellum used?	The leading edge may have been damaged. Pull out the paper roll until the damaged portion comes out and then cut it before using it.	–
Copy image is skewed.	Was the original fed straight?	Set the original referring to “● Setting the original with precision”.	3-3
	Is inclination adjustment set?	Disable the inclination adjustment.	6-1
Copy image is shifted to either side (widthwise)	Are the original guides properly set in accordance with the original size indications on the original table?	Align the original guides with the original size indications and then insert an original.	3-2
	Is the paper roll installed properly into the roll unit?	Align the flange guide positions with the appropriate size labels.	3-6
	Was the paper fed properly in the bypass mode?	Adjust the bypass guides to the paper size and then insert the copy paper.	4-8
	Was the image shift function set?	Cancel the image shift function.	5-5

TROUBLE	CHECK POINT	PROCEDURE	PAGE
Copy image is shifted to the original insertion side or the opposite side.	Was the margin copy set?	Cancel the margin copy.	5-7
	Was the image shift function set?	Cancel the image shift function.	5-5
Copy paper length is different from the specified length.	Was the margin copy set?	Cancel the margin copy.	5-7
Copies are wrinkled or curled.	Is the paper material setting correct?	Press the Media key to select the correct paper material.	4-5
	Is the paper wet?	Replace the paper roll with a new one. Depending on the operating environment, turn the dew prevention heater switch on.	3-7
	Is the roll unit flange set properly?	Set the roll unit flange properly.	3-6
	Is the fixing temperature proper?	Adjust the fixing temperature to a lower temperature.	7-2
Toner does not adhere well to the copy paper.	Is the paper material setting correct?	Press the Media key to select the correct paper material.	4-5
	Was thick paper used?	Adjust the fixing temperature to a higher temperature.	7-2
Copy film is sticky.	Is film selected as a paper material?	Press the Media key to select film.	4-5
Copy film is wavy.	Is film selected as a paper material?	Press the Media key to select film.	4-5
	Is the fixing temperature proper?	Adjust the fixing temperature to a lower temperature.	7-2
The dimensions of the copy image do not fit the dimensions of the original.	Is the paper material setting correct?	Press the Media key to select the proper paper material.	4-5
	Was the copy size adjusted?	Adjust the copy size.	7-2

CHAPTER 8 TROUBLESHOOTING

TROUBLE	CHECK POINT	PROCEDURE	PAGE
The copy image is light.	Is the copy contrast set to auto?	Adjust "Ⓢ Exposure adj." of the default setting.	7-4
	Is the exposure adjusted manually? (Is a left exposure indicator or the Light indicator lit?)	Use the copy contrast keys to adjust the exposure to the proper level.	4-3
	Is the message indicating that replenishment of toner is needed displayed?	Replenish toner.	8-3
	Is the paper wet?	Replace the paper roll with a new one. Depending on the operating environment, turn the dew prevention heater switch on.	3-7
The copy image is dark.	Is the copy contrast set to auto?	Adjust "Ⓢ Exposure adj." of the default setting.	7-4
	Is the exposure adjusted manually? (Is a right exposure indicator or the Dark indicator lit?)	Use the copy contrast keys to adjust the exposure.	4-3
Black stripes appear on copies.	Is the contact glass or the feed rollers dirty?	Clean the contact glass or the feed rollers.	9-1

CHAPTER 9 MAINTENANCE AND MANAGEMENT

1. Cleaning the Machine

⚠ CAUTION

For safety purposes, ALWAYS remove the power plug from the outlet when performing cleaning operations.

● Cleaning the original cover

If smudges on copies frequently appear, clean the contact glass and the original transport rollers.

IMPORTANT

- If the dust on the contact glass cannot be removed, wipe the glass with a cloth moistened with alcohol or weak detergent.
- Never use thinner or other solvents.

- 1 Open the original cover so that cleaning can be performed easily.

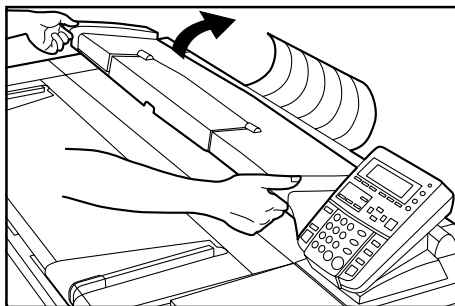

- 2 Moisten a soft cloth with water, wring the water out of the cloth, and wipe the contact glass with it.

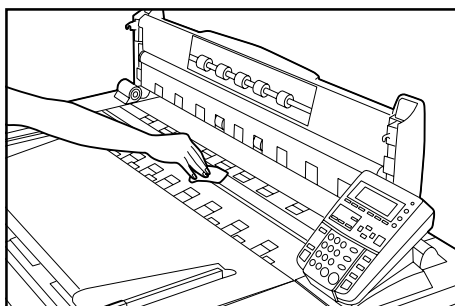

- 3 Wipe the feed rollers while turning the original transport rollers with your hand.

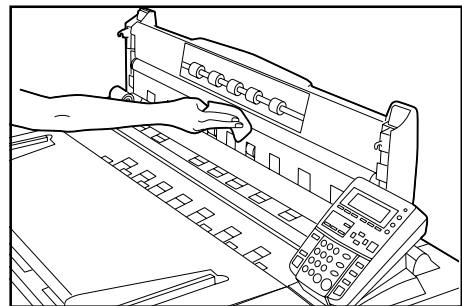

- 4 Wipe the contact glass and the original transport rollers with a soft, dry cloth.

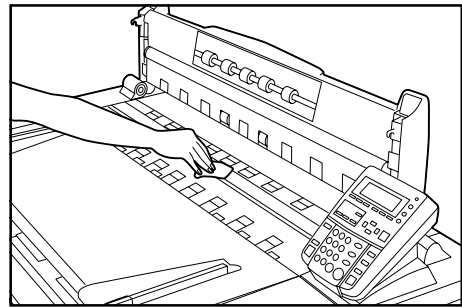

IMPORTANT

- Wipe away all mist from glass parts.

- 5 Gently close the original cover.

2. Specifications

Type	Console
Original feed system	Fixed platen
Copying system	Indirect electrostatic
Acceptable originals	Sheet
Acceptable original sizes	Maximum: 36" x 48" 36" (W) x 237" (L) A0 920 mm (W) x 6000 mm (L) Minimum: 8 1/2" x 11" 8 1/2" (W) x 11" (L) A4 (portrait) 210 mm (W) x 297 mm (L) Thickness: 64 to 80 g/m ²
Acceptable Copy Sizes	Maximum: 36" x 48" 36" (W) x 237" (L) A0 920 mm (W) x 6000 mm (L) Minimum: 8 1/2" x 11" 8 1/2" (W) x 11" (L) A4 (portrait) 210 mm (W) x 297 mm (L) Thickness: 64 to 80 g/m ² Void Area: Leading/trailing edge of paper: 10 mm or less, right/left edge of paper: 3 mm or less
Copy speed	4.8 m/minute (6.7 sheets/minute for 36" x 24" portrait [7 sheets/minute for A1 portrait])
Warm up time	Within 360 seconds (Room temperature 68°F/20°C, Humidity 65%RH)
First copy time	Within 18 seconds (36" x 24" portrait [A1 portrait])
Magnification ratio	Any ratio from 25 to 400% (in 1% or 0.1% increments), plus preset ratios
Memory for storage of image	128 MB as standard (1152 MB at the maximum)
Expansion memory	Standard 168-pin type DIMM (64 MB, 128 MB, 256 MB, 512 MB)
Paper feed system	Two roll units and bypass
Acceptable copy paper	Standard paper (64 to 80 g/m ²), vellum, film
Multiple copies	Up to 99
Reading system	Scanning exposure of moving original by means of contact image sensors (600 x 600 dpi) Light source: Xenon lamp
Writing system	LED (600 dpi x 600 dpi)
Developing system	Dry
Toner supply system	Bottle cartridge system
Fixing system	Heat roller
Cleaning system	Blade and fur brush
Photoconductor	OPC (with dew prevention heater)
Features	AMS, zoom copy, preset R/E, XY zoom, sort, group, image shift, margin copy, border erase, mirror copy, image rotation, preview copy, repeat copy, interrupt, job reserve, program, energy saver, auto shut-off, self-diagnosis
Power source	120V AC, 60 Hz, 14 A 230V AC, 50 Hz, 7 A
Power consumption	1560 W (120 V) 1620 W (230 V)
Dimensions	52 3/8" (W) x 27 11/16" (D) x 47 7/16" (H) [1330 mm (W) x 704 mm (D) x 1205 mm (H)]
Installation dimensions	52 3/8" (W) x 30 1/2" (D) [1330 mm (W) x 774 mm (D)]
Weight	Approx. 554.4 lbs./252 kg
Noise emission	≤ 70 dB (A)
Accessories	Copy bin stopper plates, original loop guide, flanges
Options	Roll unit, carrier sheet, original tray, printer/scanner controller, key counter, and expansion memory

(Specifications are subject to change without notice.)

CAUTION!

The power plug is the main isolation device! Other switches on the equipment are only functional switches and are not suitable for isolating the equipment from the power source.

VORSICHT!

Der Netzstecker ist die Hauptisoliervorrichtung! Die anderen Schalter auf dem Gerät sind nur Funktionsschalter und können nicht verwendet werden, um den Stromfluß im Gerät zu unterbrechen.

LICHT EMITTIERENDE DIODE KLASSE 1
LIGHT EMITTING DIODE CLASS 1



DECLARATION OF CONFORMITY

TO

89/336/EEC, 73/23/EEC and 93/68/EEC

We declare under our sole responsibility that the product to which this declaration relates is in conformity with the following specifications.

Limits and methods of measurement for immunity characteristics of information technology equipment	<u>EN55024</u>
Limits and methods of measurement for radio interference characteristics of information technology equipment	<u>EN55022 Class B</u>
Limits for harmonic currents emissions for equipment input current ≤ 16 A per phase	<u>EN61000-3-2</u>
Limitation of voltage fluctuations and flicker in low-voltage supply systems for equipment with rated current ≤ 16 A	<u>EN61000-3-3</u>
Safety of information technology equipment, including electrical equipment	<u>EN60950</u>

* For best copy results and machine performance, we recommend that you use only KYOCERA MITA original supplies for your KYOCERA MITA copier.

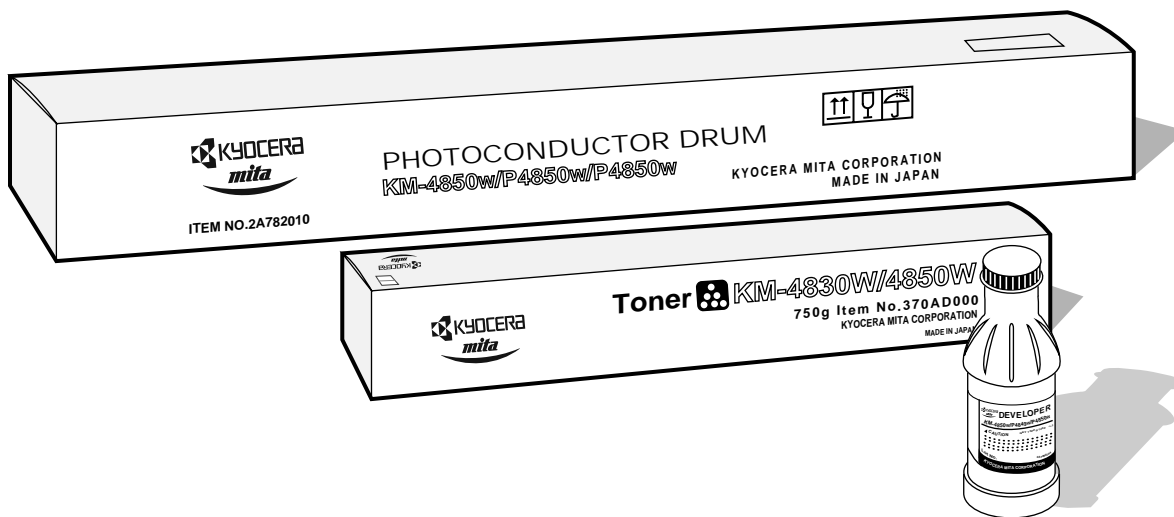

**QUALITY
CERTIFICATE**

This machine has passed
all quality controls and
final inspection.

KYOCERA MITA EUROPE B.V.

Hoeksteen 40, 2132 MS Hoofddorp,
The Netherlands
Phone: (020) 6540000
Home page: <http://www.kyoceramita-europe.com>
Email: info@kyoceramita-europe.com

KYOCERA MITA NEDERLAND B.V.

Hoeksteen 40, 2132 MS Hoofddorp,
The Netherlands
Phone: (020) 5877200

KYOCERA MITA (UK) LIMITED

8 Beacontree Plaza
Gillette Way,
Reading RG2 0BS UK
Phone: (0118) 931 1500

KYOCERA MITA ITALIA S.P.A.

Via Verdi 89/91 20063 Cernusco sul Naviglio
(Milano) Italy
Phone: 02-92179 1

S.A. KYOCERA MITA BELGIUM N.V.

Hermesstraat 8A, 1930 Zaventem, Belgium
Phone: (02) 7209270

KYOCERA MITA FRANCE S.A.

Parc les Algorithmes
SAINT AUBIN
91194 GIF-SUR-YVETTE
France
Phone: (01) 69852600

KYOCERA MITA ESPAÑA S.A.

Edificio Mita, Avda. De Manacor Nº2,
Urb. Parque Rozas, Apartado de Correos 76,
28230 Las Rozas, Madrid, Spain
Phone: (91) 631-8392

KYOCERA MITA FINLAND OY

Kirvesmiehenkatu 4, 00810 Helsinki,
Finland
Phone: (09) 478-05200

KYOCERA MITA (SCHWEIZ) AG

Hözlwiisen, Industriestrasse 28,
8604 Volketswil, Switzerland
Phone: (01) 908 4949

KYOCERA MITA DEUTSCHLAND GMBH

Mollsfeld 12 40670 Meerbusch,
Germany
Phone: 02159-918120

KYOCERA MITA GMBH AUSTRIA

Eduard-Kittenberger-Gasse 95,
1230, Wien, Austria
Phone: (01) 86338-0

KYOCERA MITA SVENSKA AB

Siktgatan 2,
162 50 Vällingby, Sweden
Phone: (08) 4719999

KYOCERA MITA DANMARK A/S

Industrivej 11, DK-4632 Bjæverskov,
Denmark
Phone: 56871100

KYOCERA MITA PORTUGAL LDA.

CASCAISTOCK-Armazem nº8,
Rua das Fugas, Alcoitão,
2765 Estoril, Portugal
Phone: (21) 4602221

KYOCERA MITA SOUTH AFRICA (PTY) LTD.

UNIT 3, "Kyalami Crescent,"
Kyalami Business Park,
1685 Midrand, South Africa
Phone: (11) 466-3290

KYOCERA MITA AMERICA, INC.

Headquarters:

225 Sand Road, P.O. Box 40008,
Fairfield, New Jersey 07004-0008,
U.S.A.
Phone: (973) 808-8444

KYOCERA MITA AUSTRALIA PTY. LTD.

Level 3, 6-10 Talavera Road, North Ryde,
N.S.W. 2113 Australia
Phone: (02) 9888-9999

KYOCERA MITA NEW ZEALAND LTD.

1-3 Parkhead Place,
Albany, Auckland,
New Zealand
Phone: (09) 415-4517

KYOCERA MITA (THAILAND) CORP., LTD.

9/209 Ratchada-Prachachem Road,
Bang Sue, Bangkok 10800, Thailand
Phone: (02) 586-0320

KYOCERA MITA SINGAPORE PTE LTD.

121 Genting Lane, 3rd Level,
Singapore 349572
Phone: (65) 7418733

KYOCERA MITA HONG KONG LIMITED

11/F., Mita Centre,
552-566, Castle Peak Road,
Tsuen Wan, New Territories,
Hong Kong
Phone: (852) 24297422

KYOCERA MITA CORPORATION

2-28, 1-chome, Tamatsukuri, Chuo-ku
Osaka 540-8585, Japan
Phone: (06) 6764-3555